



THE  
ORIENTAL  
INSTITUTE  
OF THE UNIVERSITY OF CHICAGO

# Building the Pyramids

Joseph Cross

Ph.D. student, Egyptology and Hebrew Bible

Oriental Institute

University of Chicago





# Old Kingdom (2700 to 2150 BCE)



# Middle Kingdom (2000 to 1650 BCE)

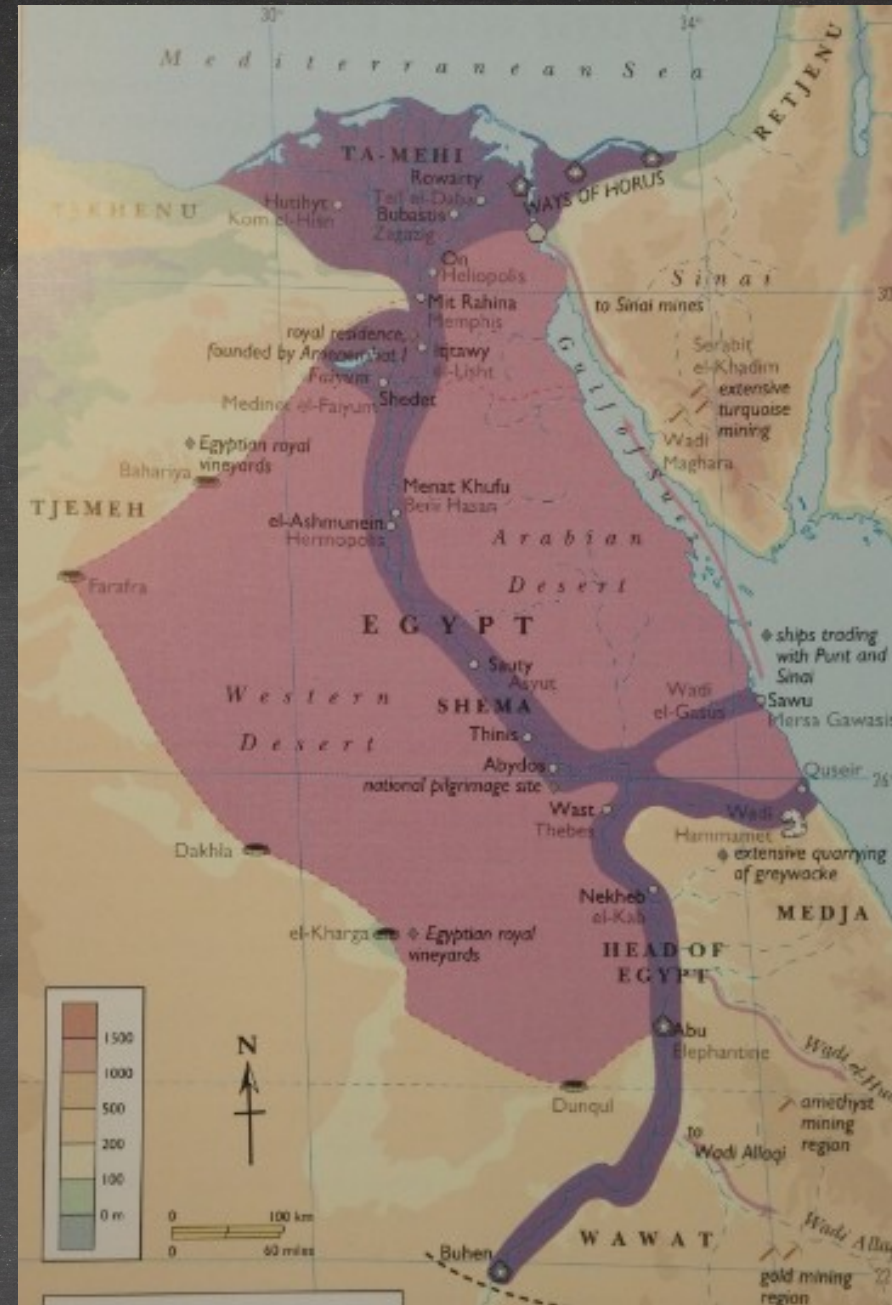

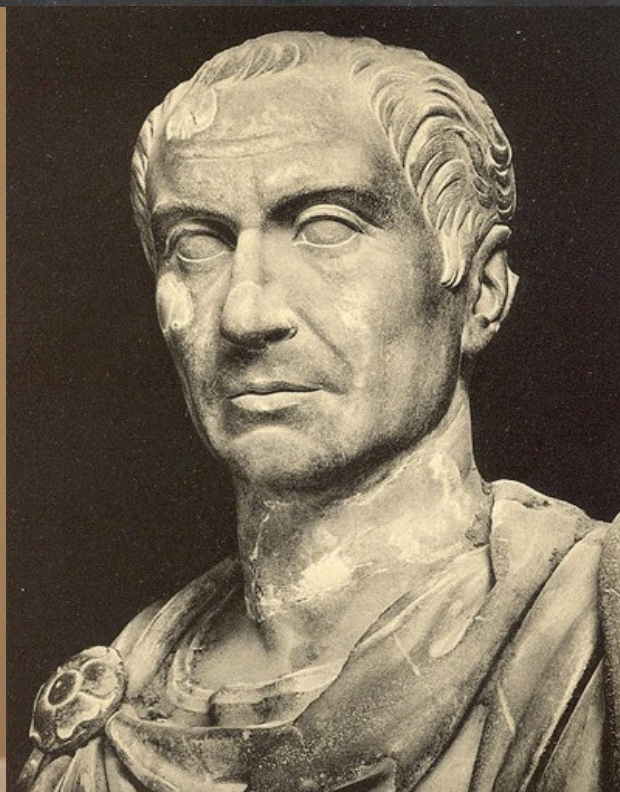

# Seven Wonders of the Ancient World



# Seven Wonders of the Ancient World





# Great Pyramid Of Khufu (Cheops)



- 500 ft tall
- 2 million bricks

# Great Pyramid Of Khufu (Cheops)

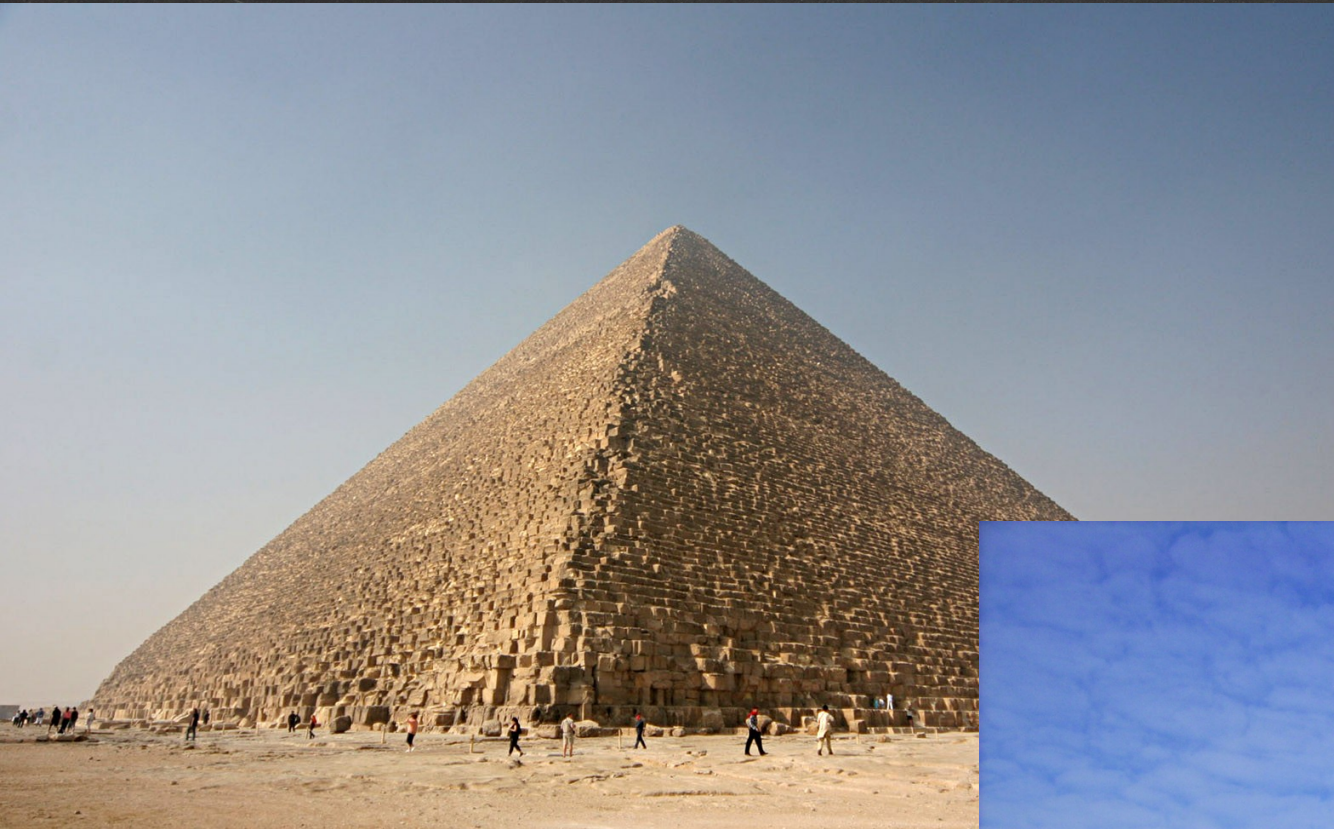



How were they built?

How were they built?





Limestone

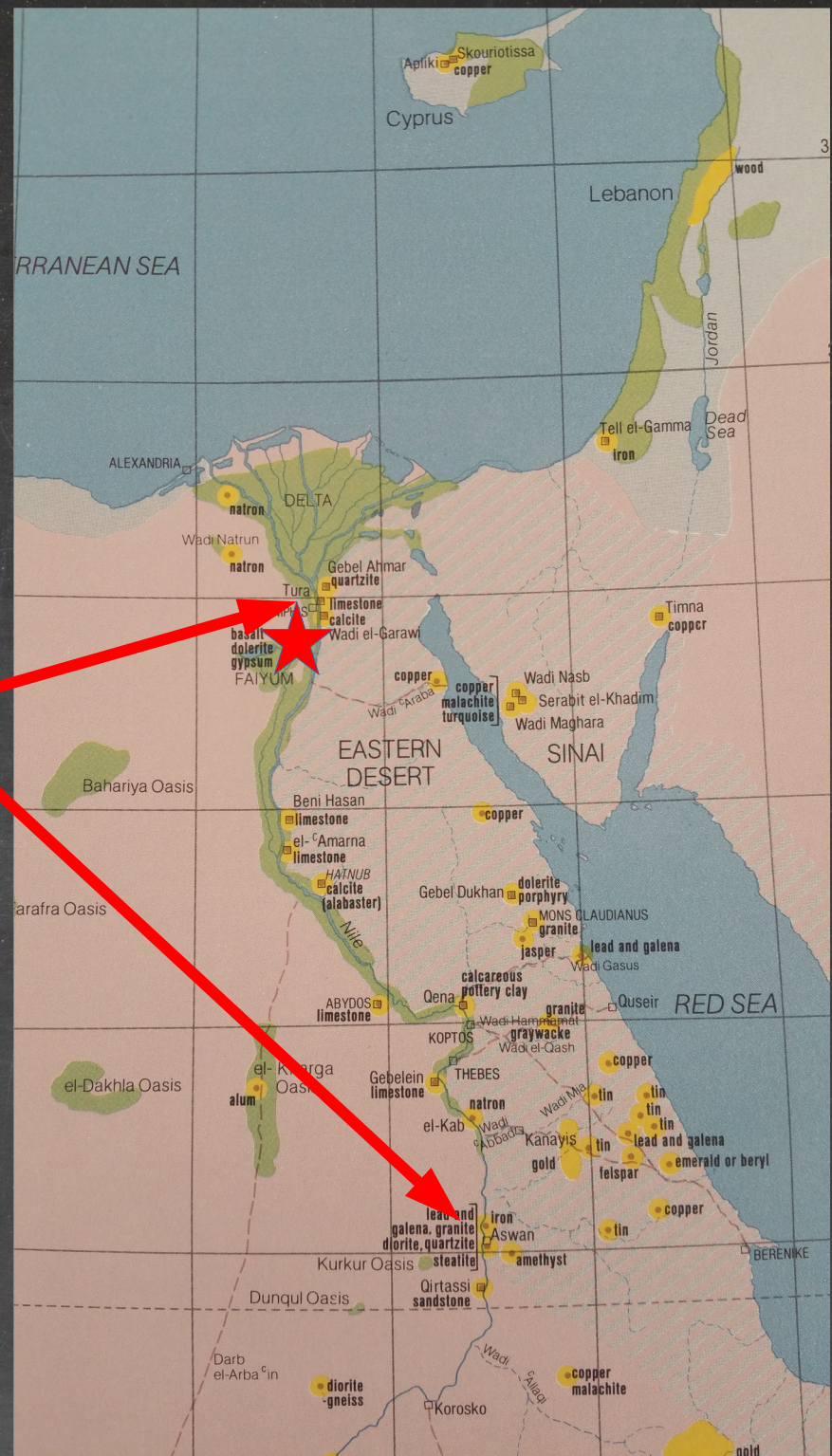



Gypsum





Copper







Cedar wood

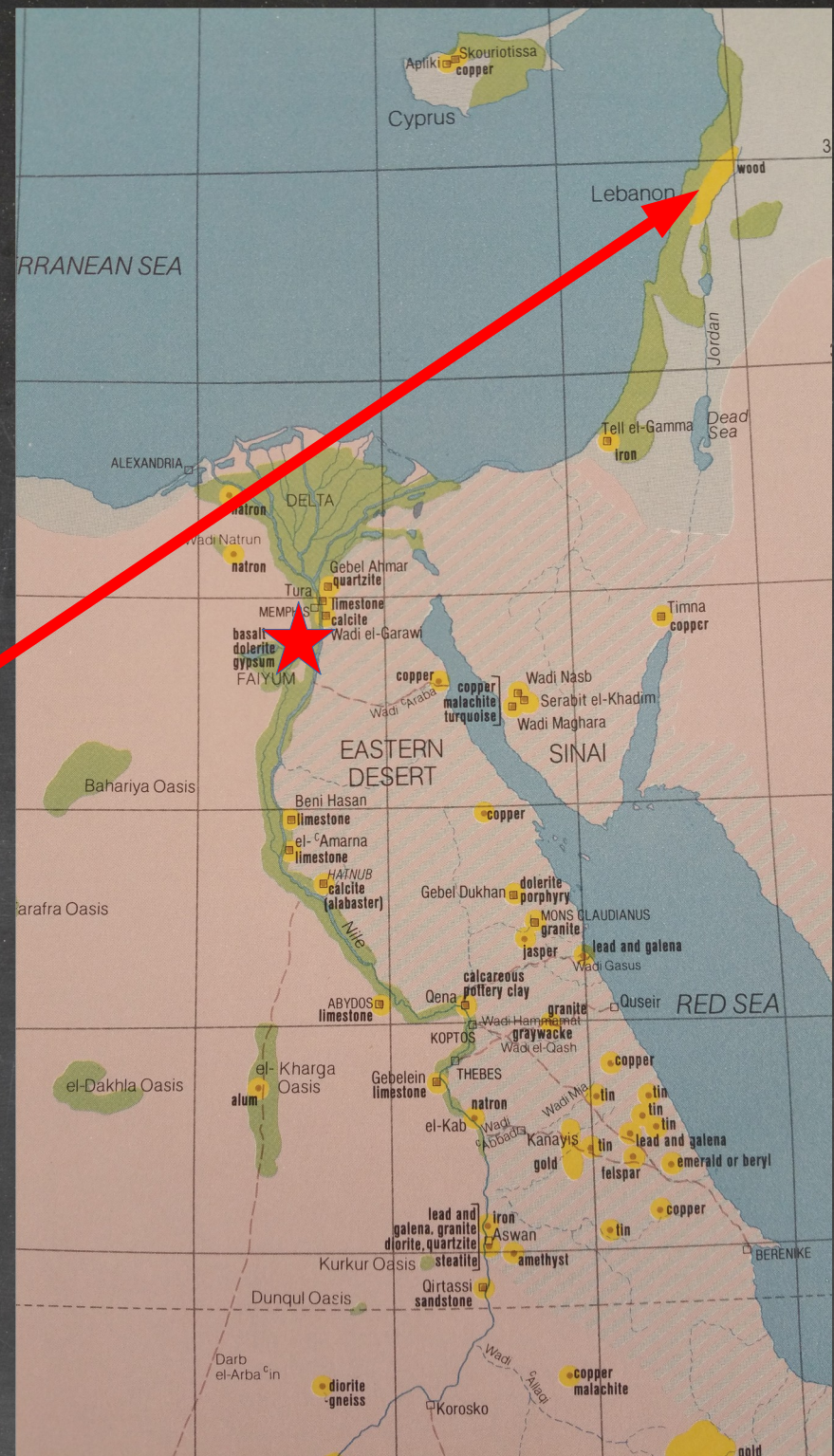



Grain

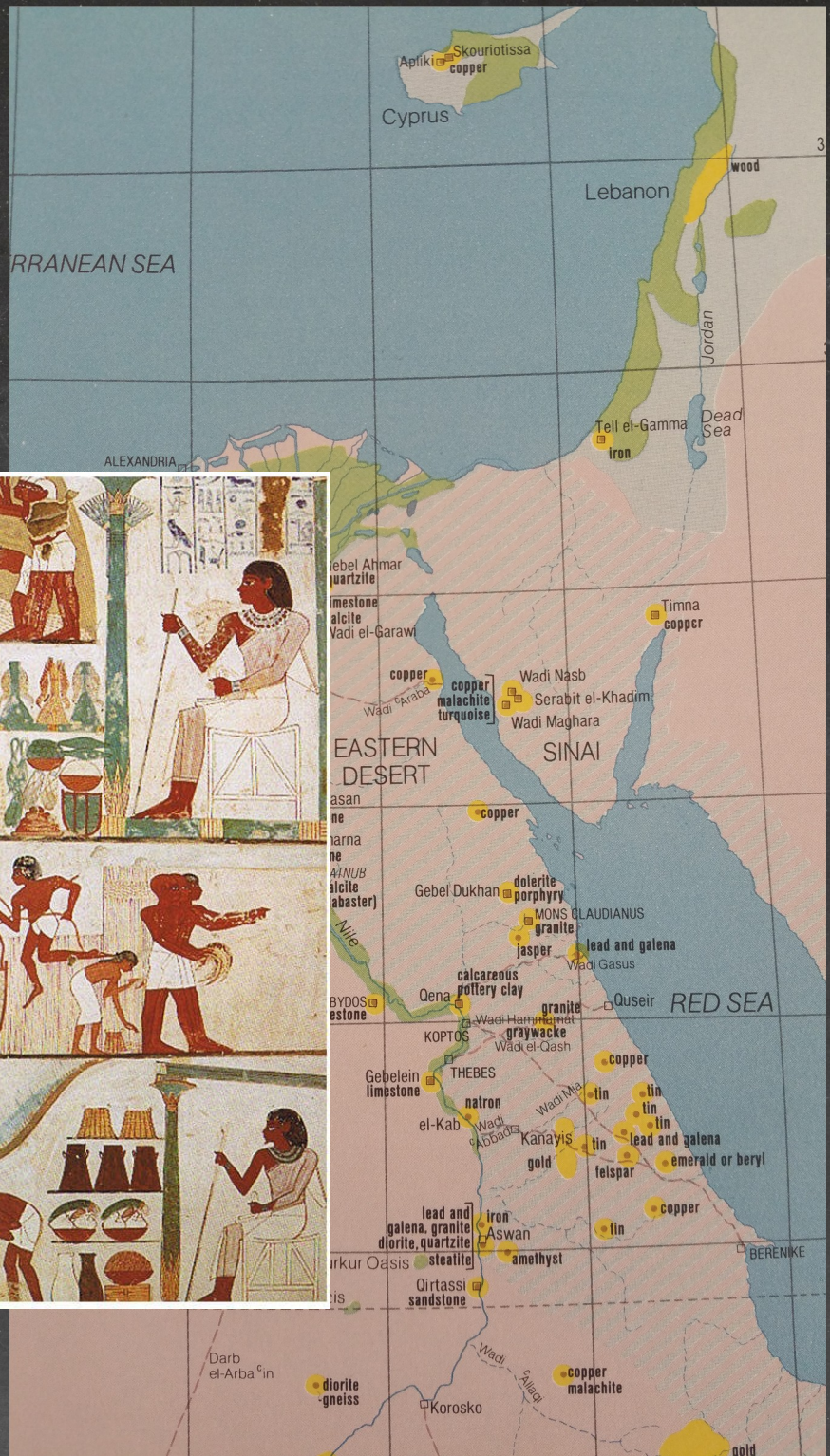



# Quarrying



# Quarrying



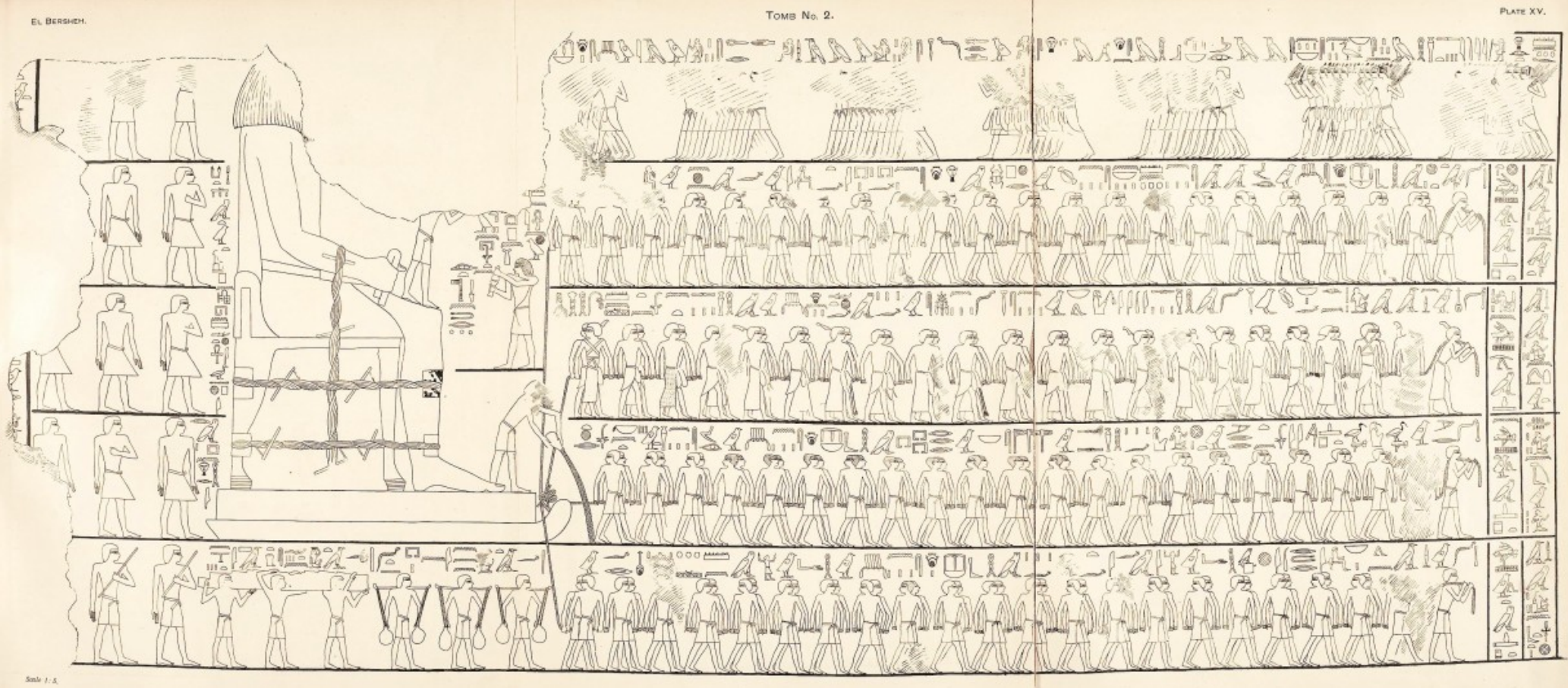

From the tomb of Thuthotep at Deir el-Bersha (Middle Kingdom)

# Quarrying



# Transportation of stone





# Preparing the site

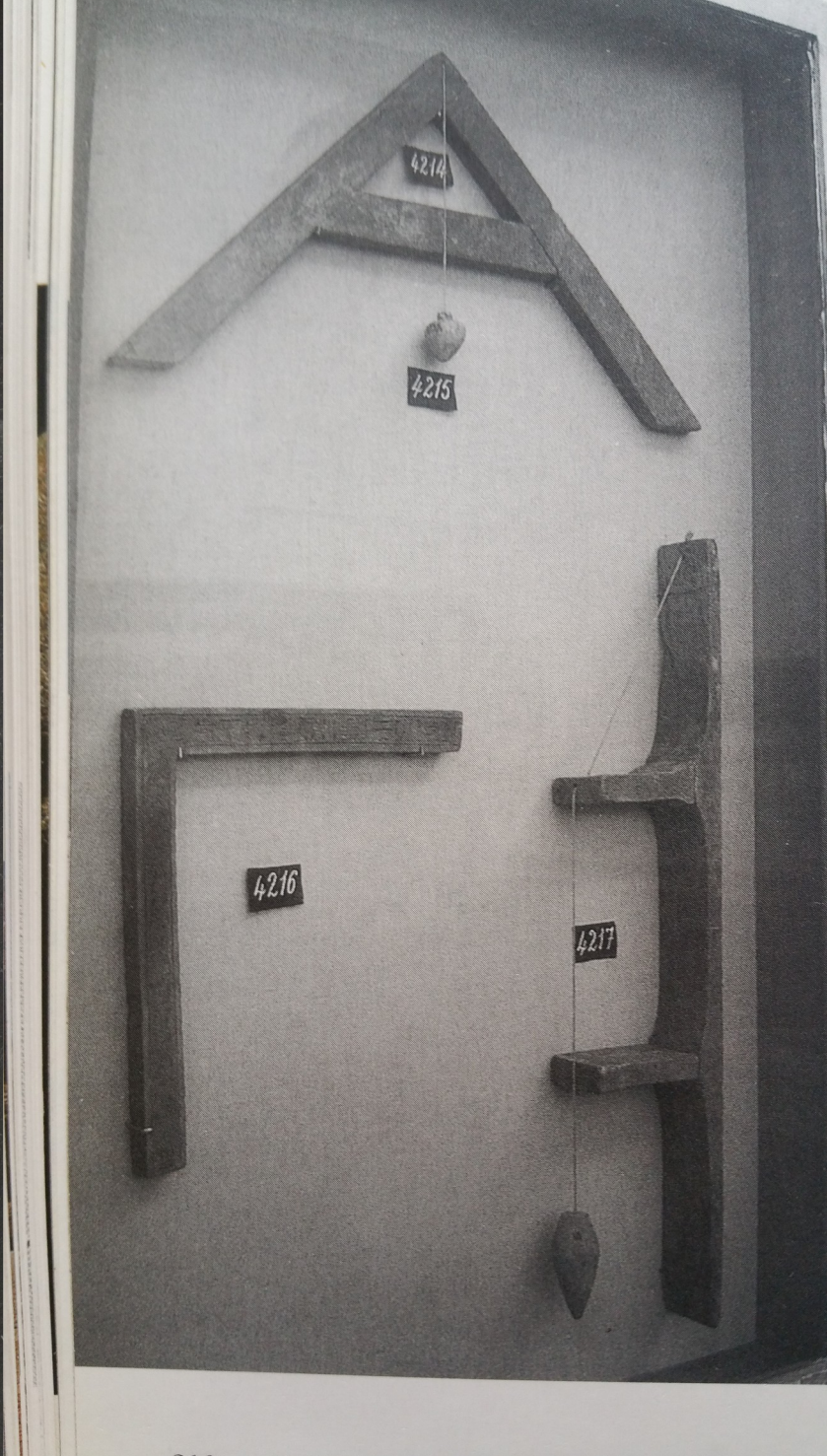



KEY

- |                          |   |
|--------------------------|---|
| 1 Great Pyramid of Khafu | 8 causeway to valley temple   |
| 2 ramps                  | 9 town  |
| 3 housing for workers    | 10 tombs of royal relatives and officials                           |
| 4 supply tracks          | 11 future sites of pyramids of Menkaure and Khafu and of the Sphinx |
| 5 harbor, canal          |   |
| 6 waste quarry           |   |
| 7 Khafu's palace complex |   |

# Placement of stones

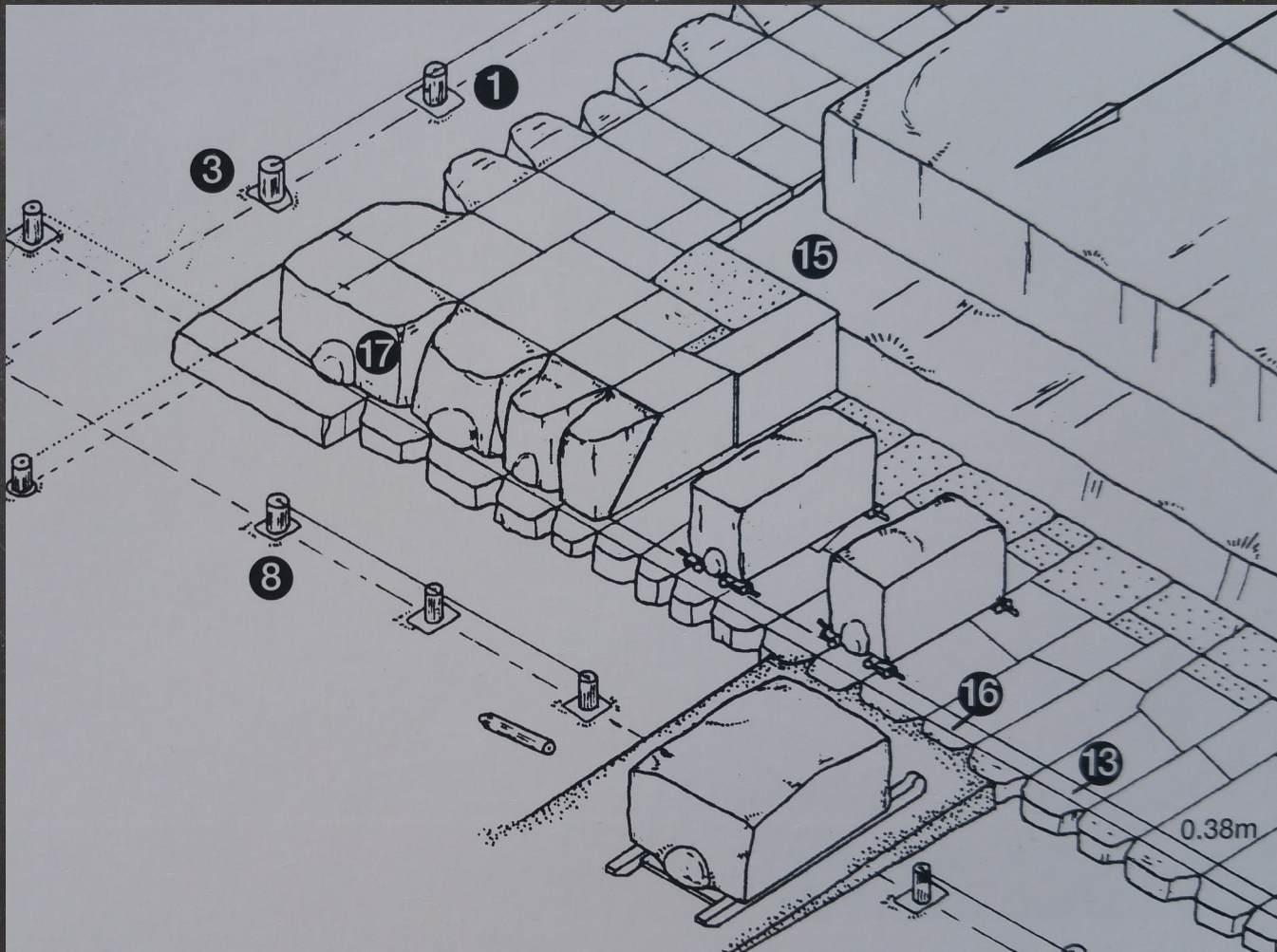

# Placement of stones

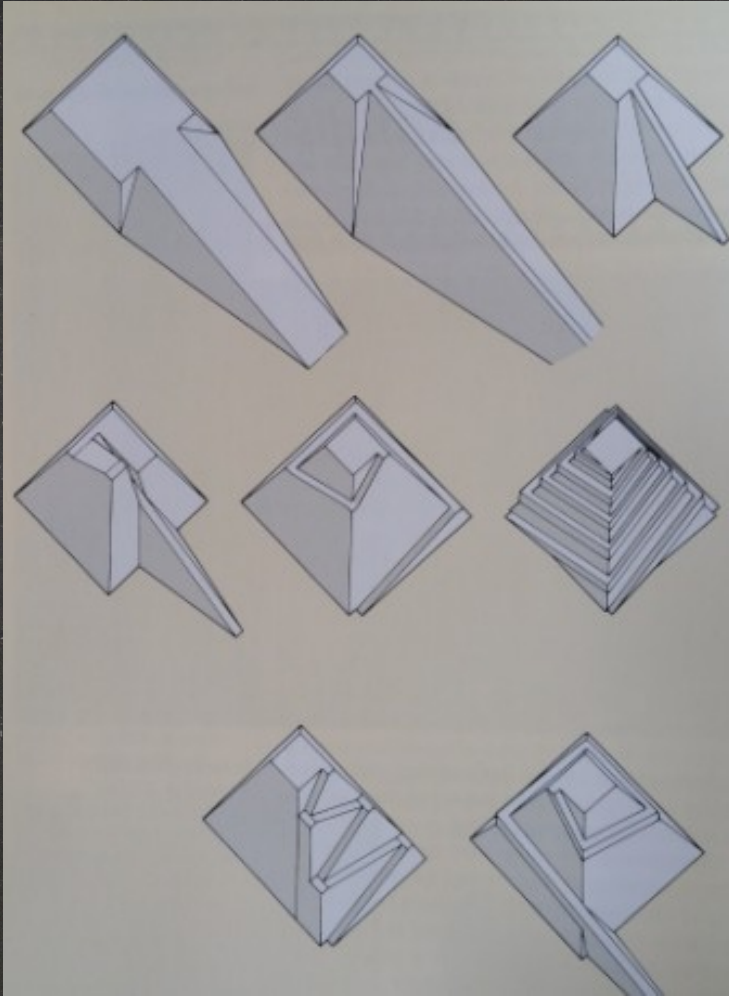

# Placement of stones

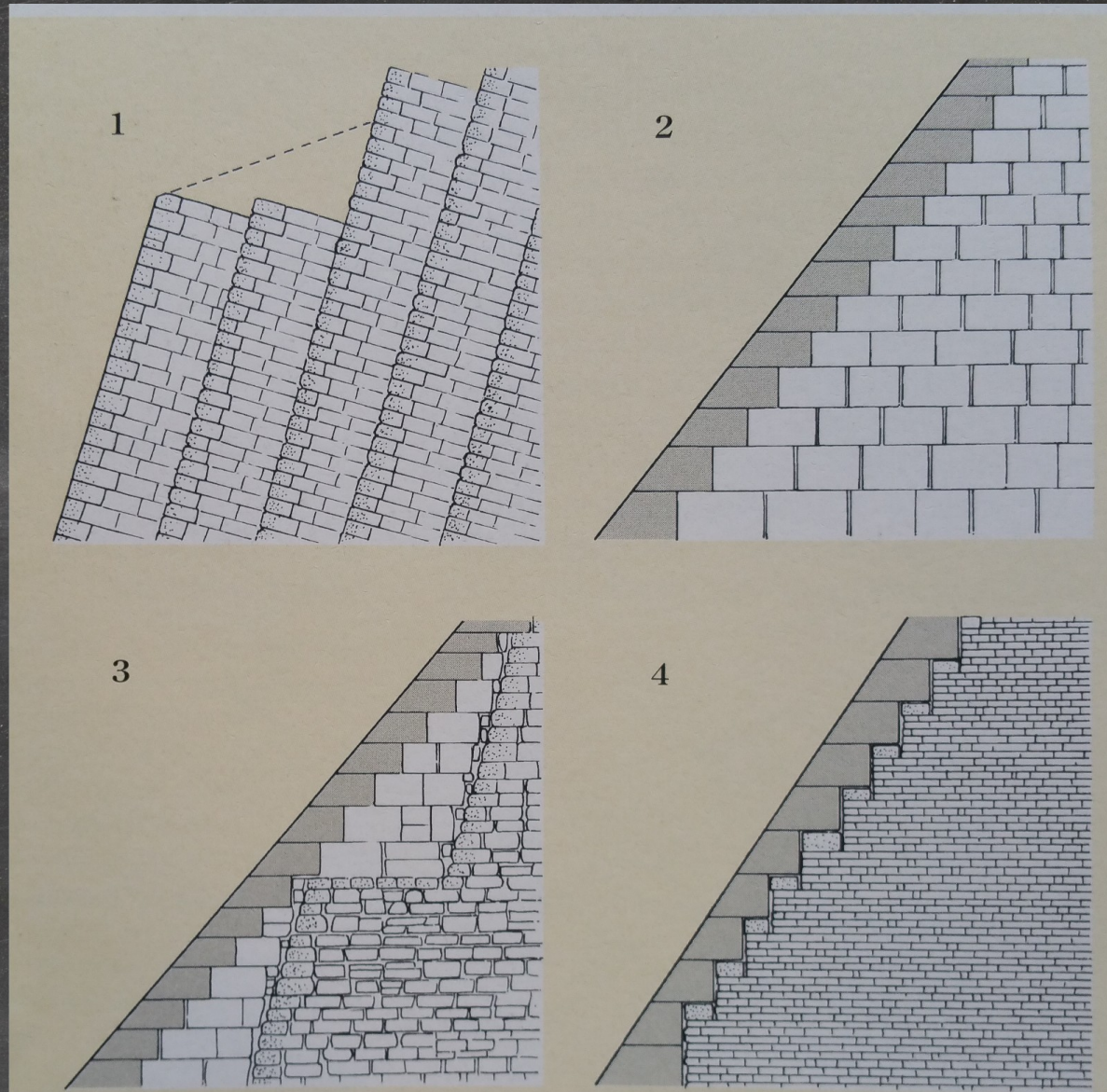

# Placement of stones



# Topping it off

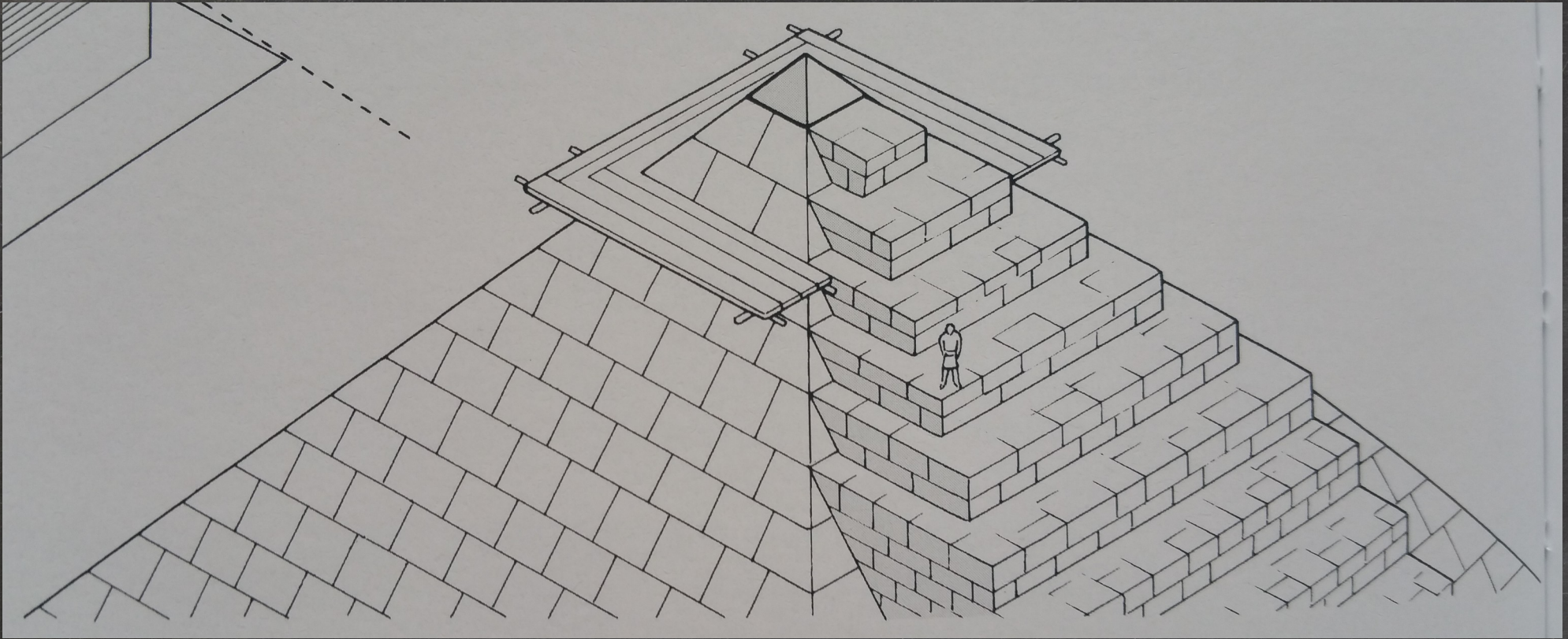

# How much arithmetic did it take?

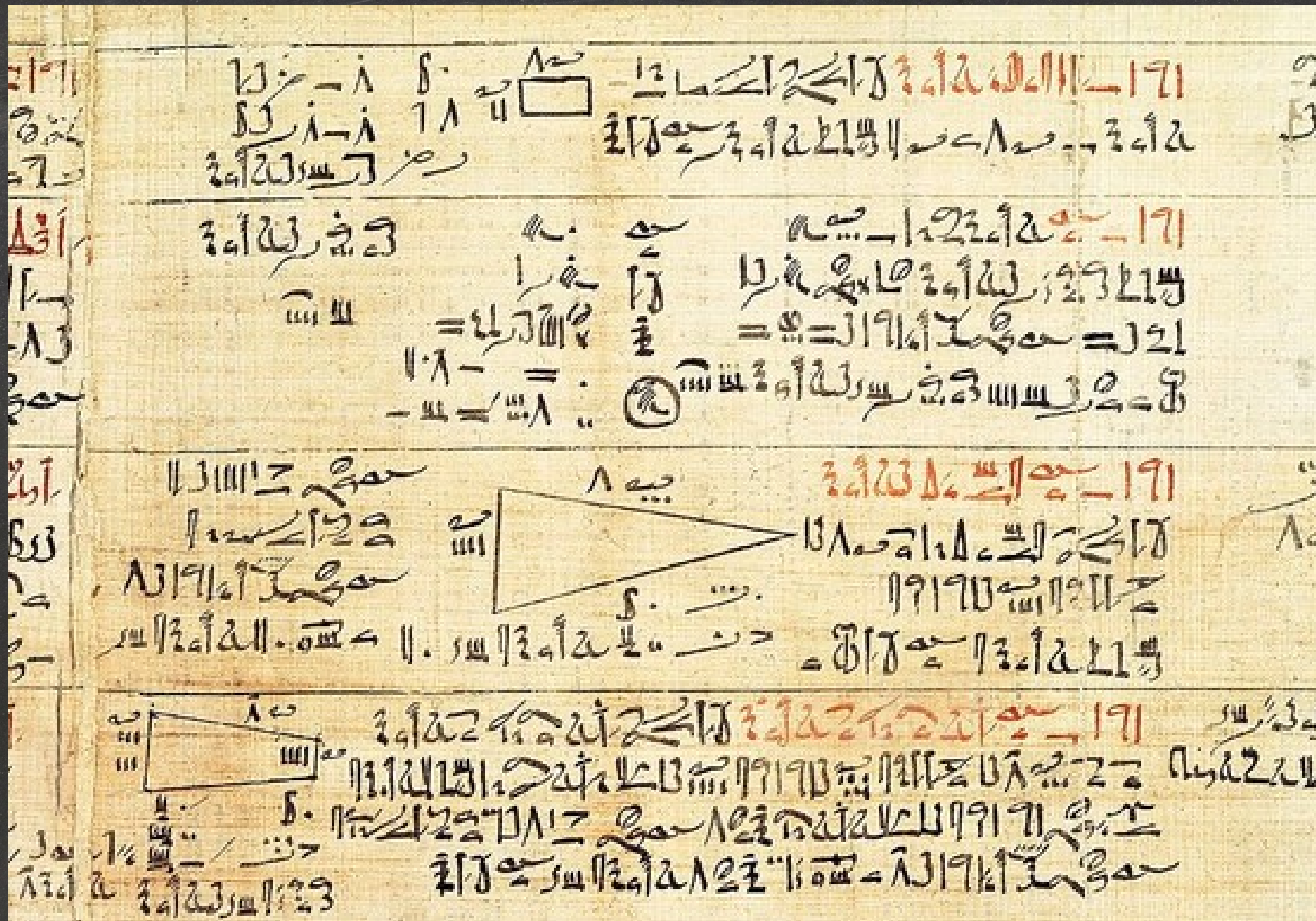



# How did they work together?

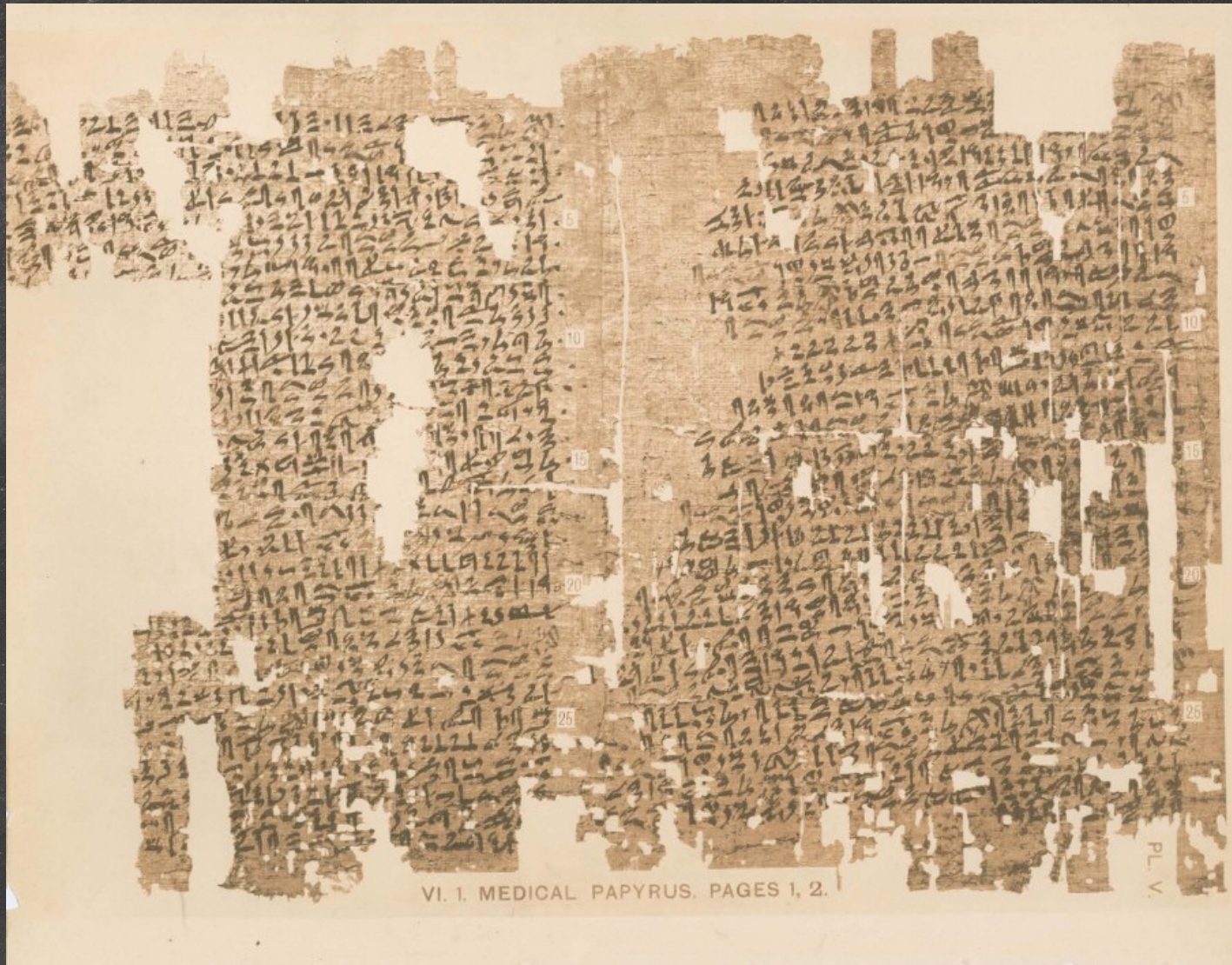

2,000 crew

1,000 gang  
'Friends of  
Menkaure'

1,000 gang  
'Drunkards of  
Menkaure'

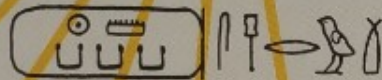

200 phyle  
'Great' 'Asiatic' 'Green' 'Little' 'Last'

200 phyle  
'Great' 'Asiatic' 'Green' 'Little' 'Last'

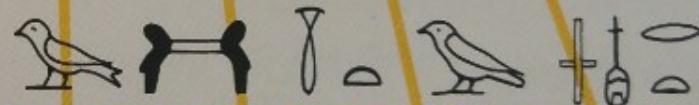

(20 men x 10 in each phyle)

(20 men x 10 in each phyle)

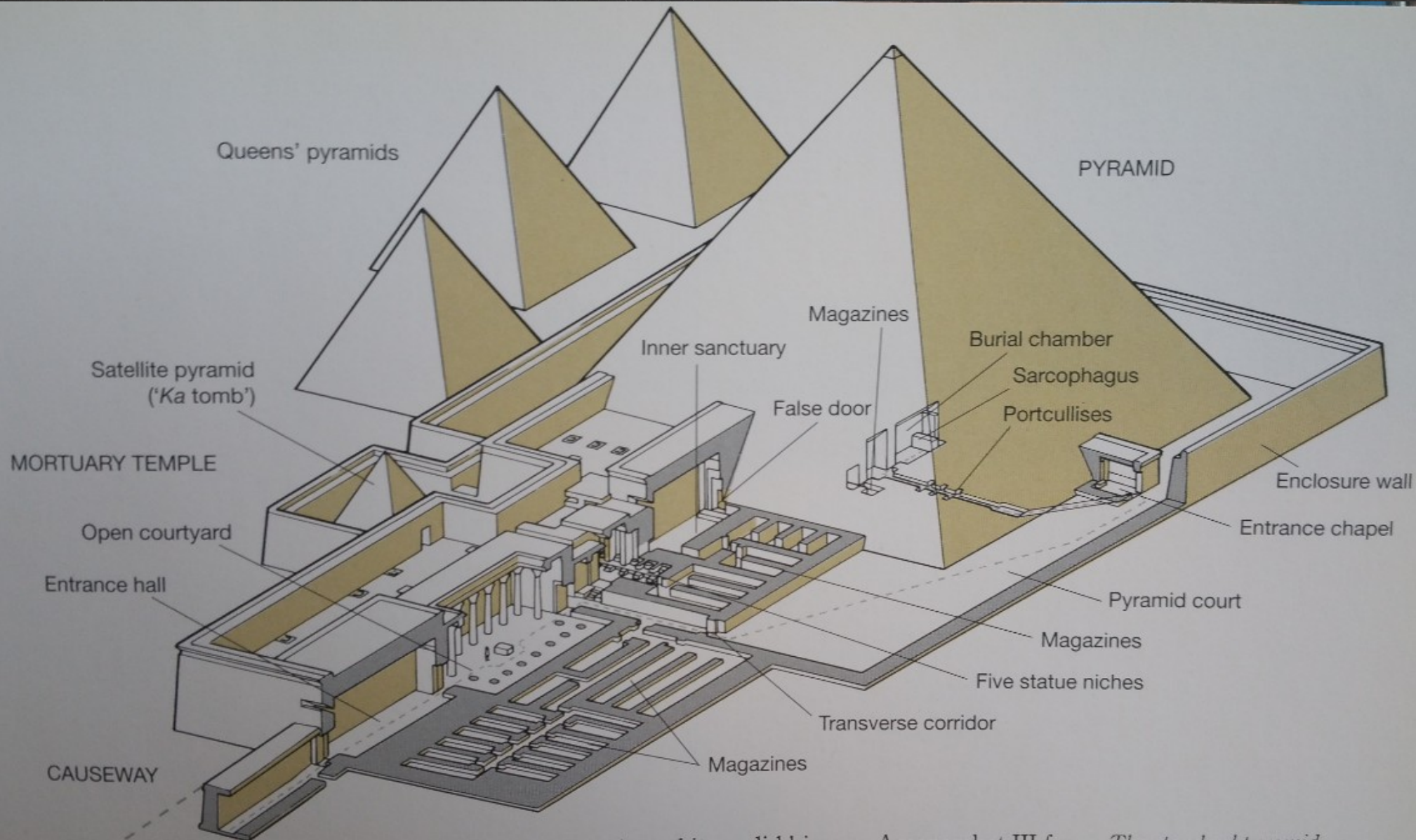





What did the pyramid symbolize?

What did the pyramid symbolize?



# What did the pyramid symbolize?





# A brief tour of the pyramids

# Step Pyramid of Djoser



in the 12th dynasty Senwos-

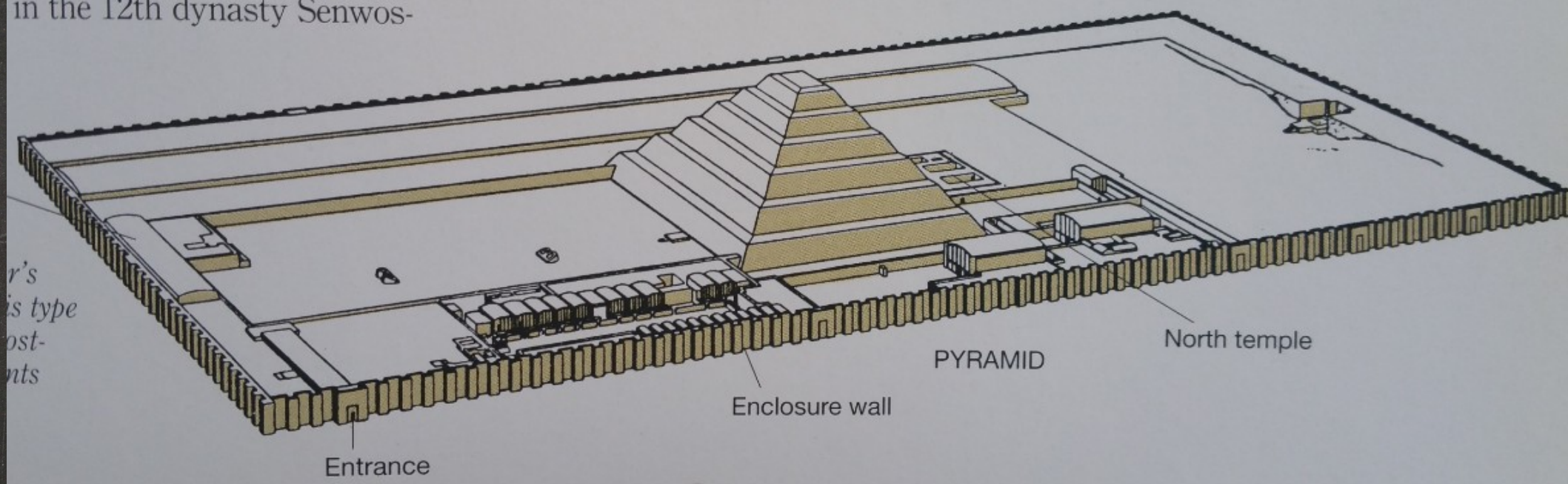

r's  
is type  
ost-  
nts

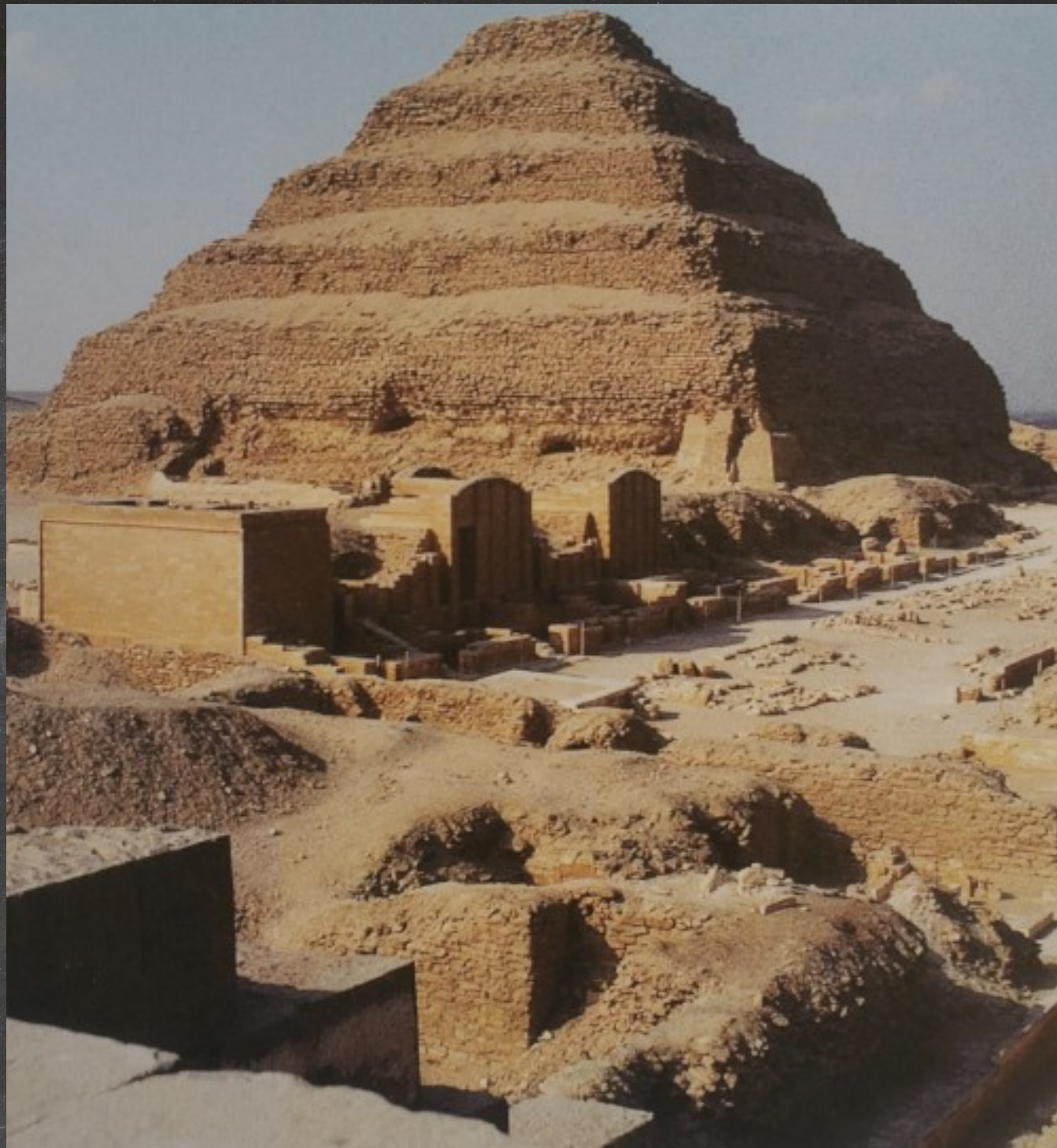



*Djoser Underground*

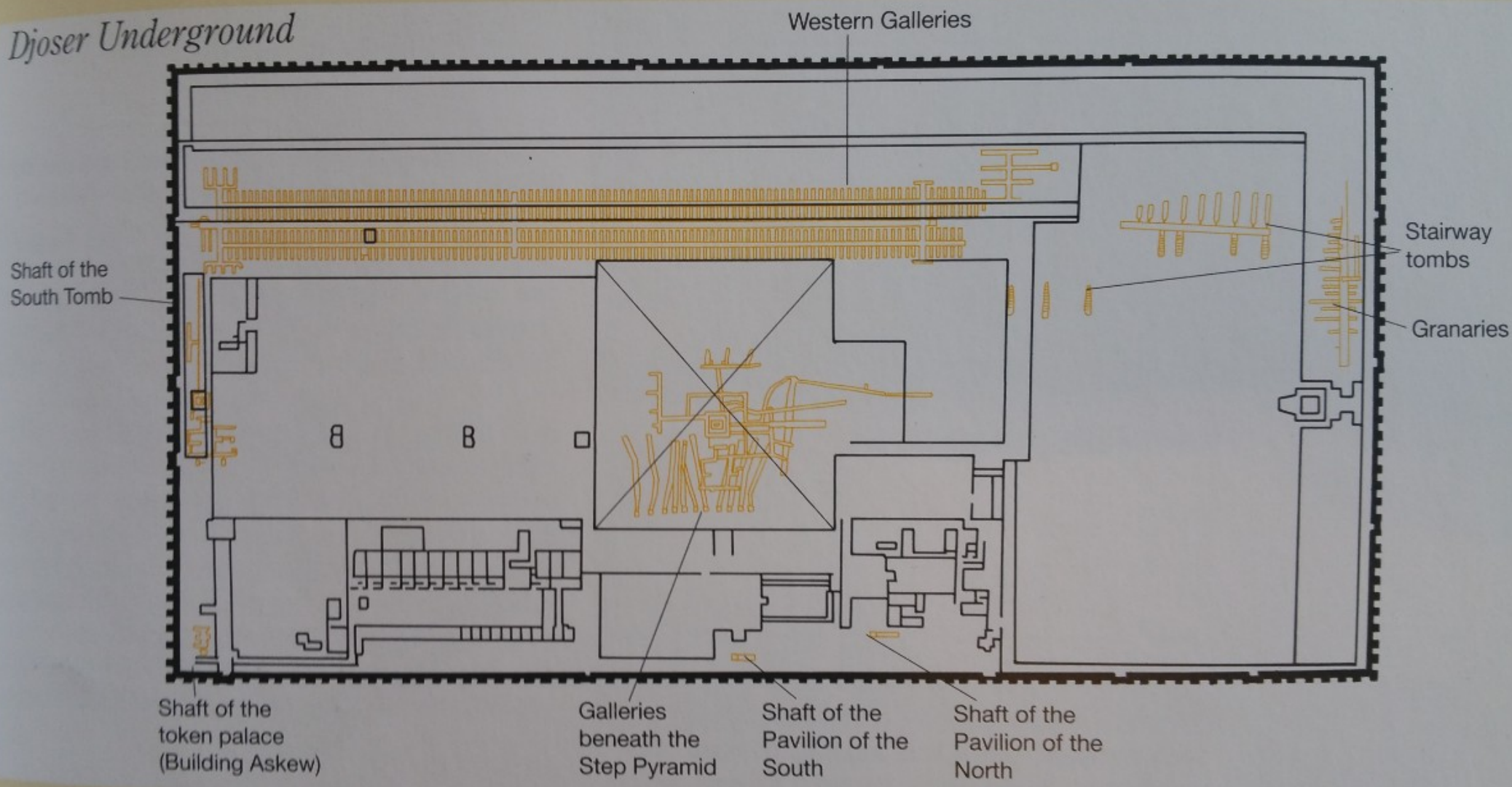

Western Galleries

Shaft of the South Tomb

Stairway tombs

Granaries

Shaft of the token palace (Building Askew)

Galleries beneath the Step Pyramid

Shaft of the Pavilion of the South

Shaft of the Pavilion of the North

# Meidum Pyramid of Sneferu



*court were left blank, perhaps because of the rise to power of the powerful and ambitious Khufu.*

Burial chamber, 5.9 x 2.65 m, h. 5.05 m, corbelled

'Tower' visible today

Entrance

Eastern chapel, 9.18 x 9 m, h. 2.7 m

Vertical shaft, h. 6.5 m

Descending passage: 58 m long; 0.85 m wide; h. 1.65 m

Horizontal passage with two recesses for plug blocks

N

never finished.  
the chamber at  
more logs, one  
have assisted in  
trace of a sarco  
Petrie recovered  
early plain style  
are now in Univ

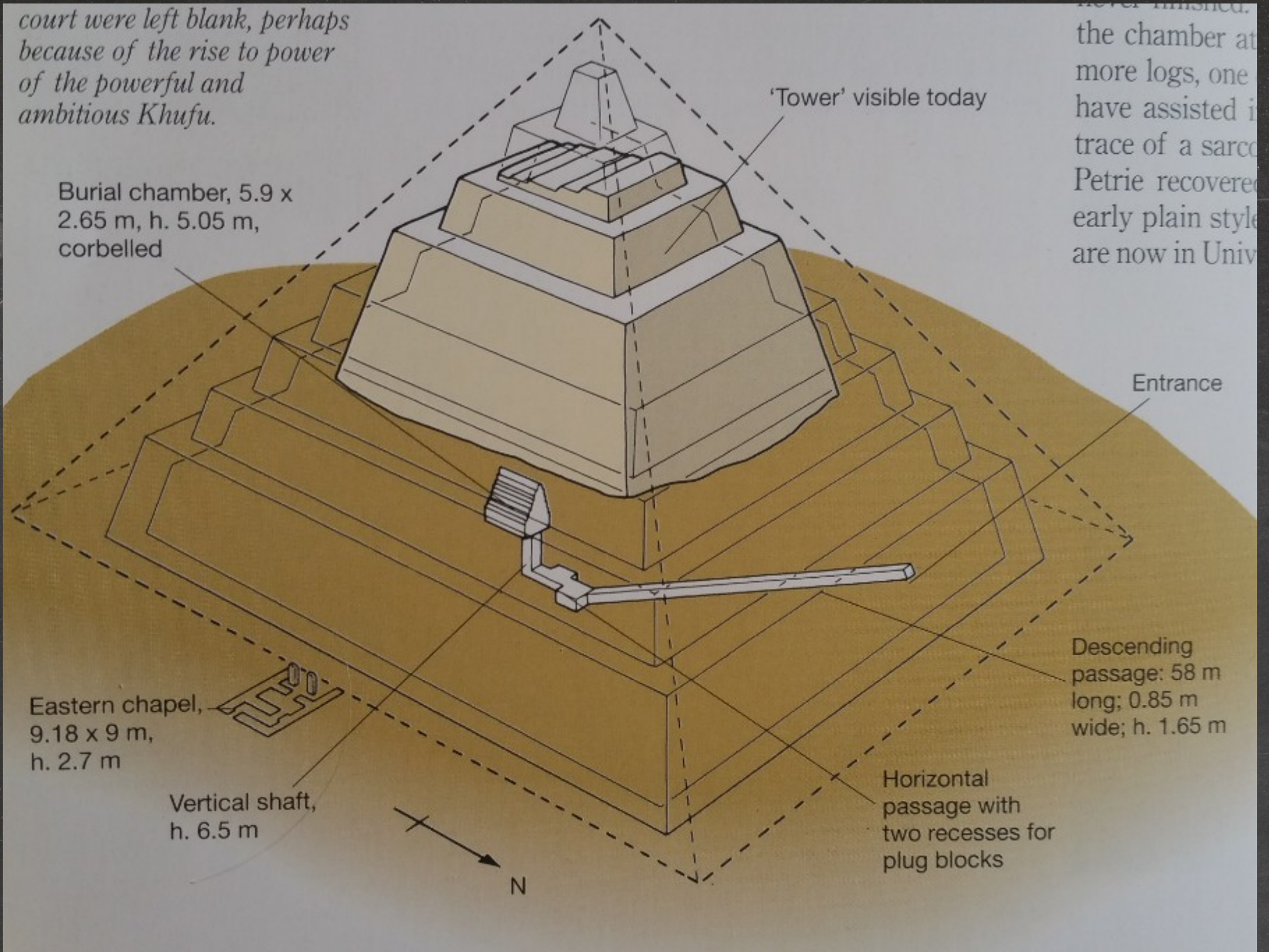



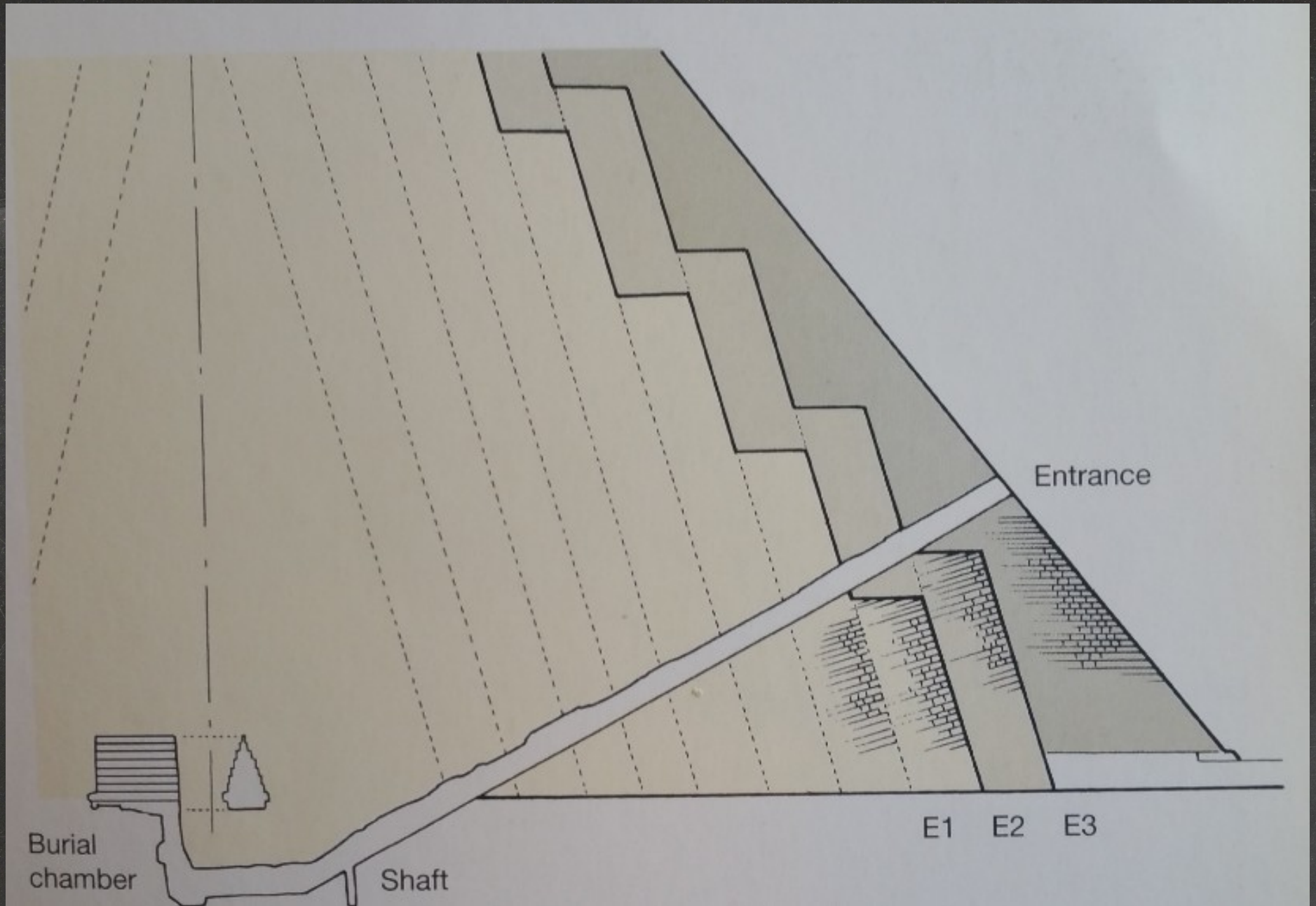

# Bent pyramid of Sneferu



angle of slope was  $54^{\circ} 27'$   
 $44''$  up to the bend, and  $43^{\circ}$   
 $22'$  thereafter.

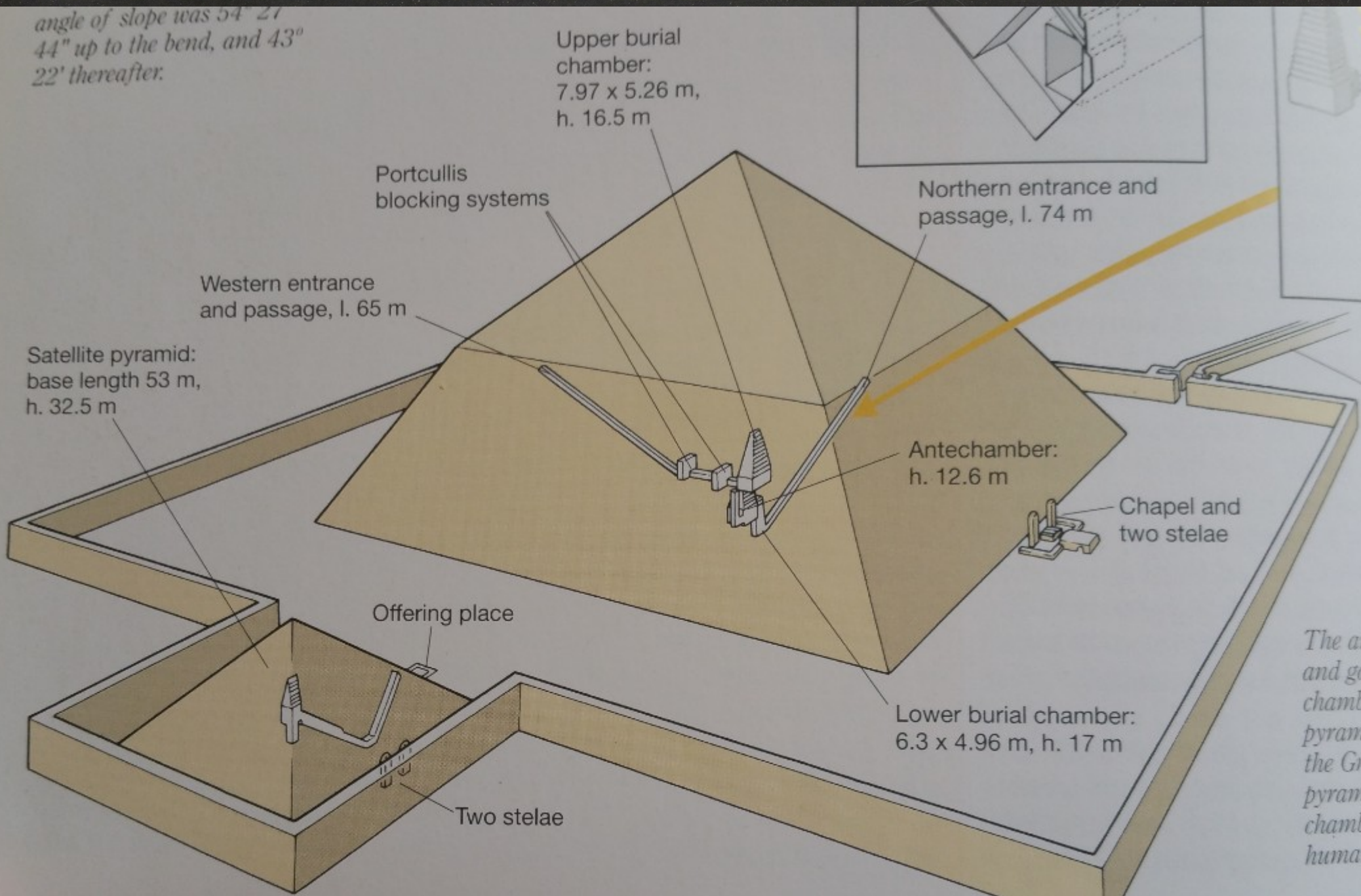

Upper burial chamber:  
7.97 x 5.26 m,  
h. 16.5 m

Portullis  
blocking systems

Northern entrance and  
passage, l. 74 m

Western entrance  
and passage, l. 65 m

Satellite pyramid:  
base length 53 m,  
h. 32.5 m

Antechamber:  
h. 12.6 m

Chapel and  
two stelae

Offering place

Lower burial chamber:  
6.3 x 4.96 m, h. 17 m

Two stelae

The ar  
and gal  
chambe  
pyrami  
the Gra  
pyrami  
chambe  
human

# Red pyramid of Sneferu







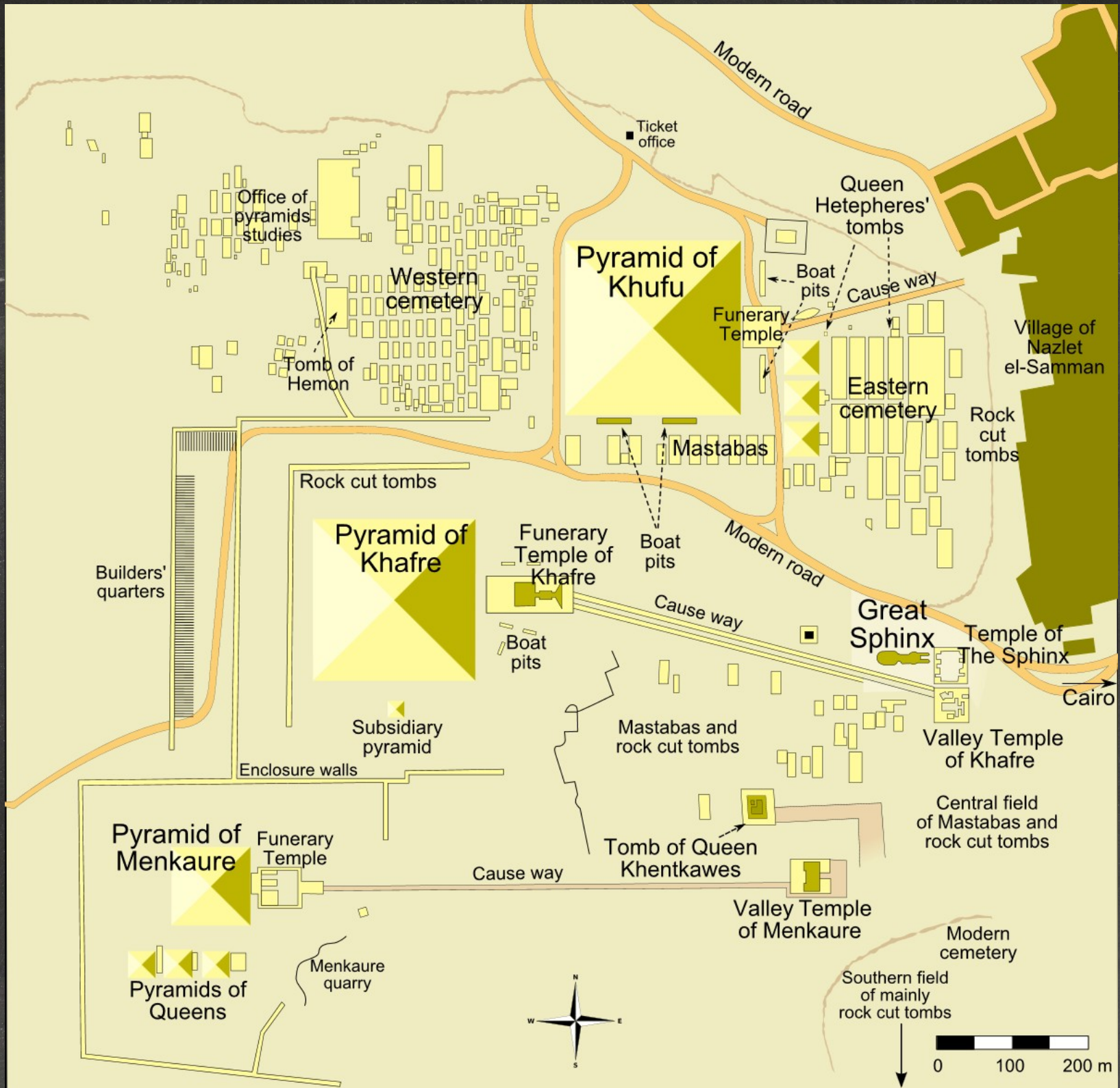

Pyramid of Khufu

Pyramid of Khafre

Pyramid of Menkaure

Pyramids of Queens

Western cemetery

Eastern cemetery

Great Sphinx

Temple of The Sphinx

Valley Temple of Khafre

Valley Temple of Menkaure

Modern cemetery

Southern field of mainly rock cut tombs

Pyramid of Khufu

Pyramid of Khafre

Pyramid of Menkaure

Pyramids of Queens

Western cemetery

Eastern cemetery

Great Sphinx

Temple of The Sphinx

Valley Temple of Khafre

Valley Temple of Menkaure

Modern cemetery

Southern field of mainly rock cut tombs

Ticket office

Office of pyramids studies

Tomb of Hemon

Queen Hetepheres' tombs

Funerary Temple

Mastabas

Funerary Temple of Khafre

Builders' quarters

Rock cut tombs

Subsidiary pyramid

Enclosure walls

Mastabas and rock cut tombs

Tomb of Queen Khentkawes

Central field of Mastabas and rock cut tombs

Menkaure quarry

0 100 200 m



Cairo

Modern road

Modern road

Cause way

Cause way

Cause way

Boat pits

Boat pits

Boat pits

Rock cut tombs

Village of Nazlet el-Samman

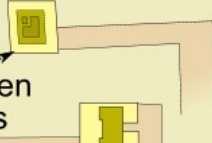
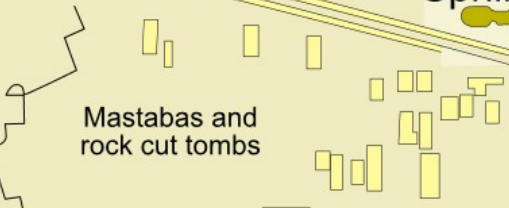
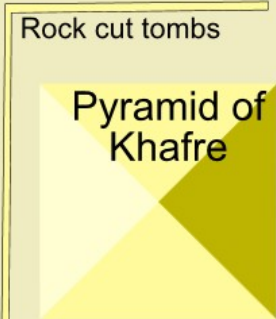
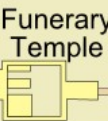
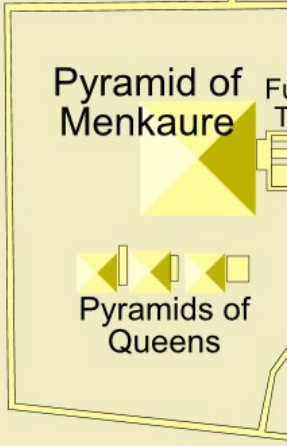
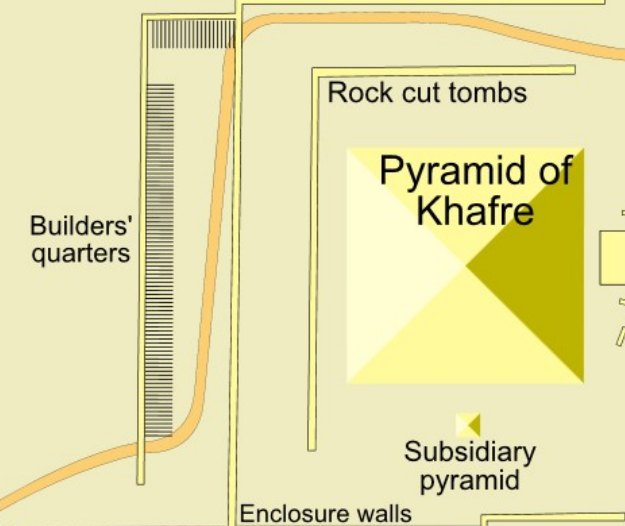
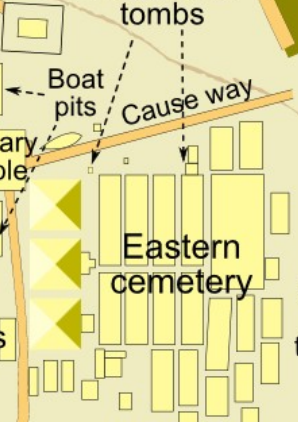
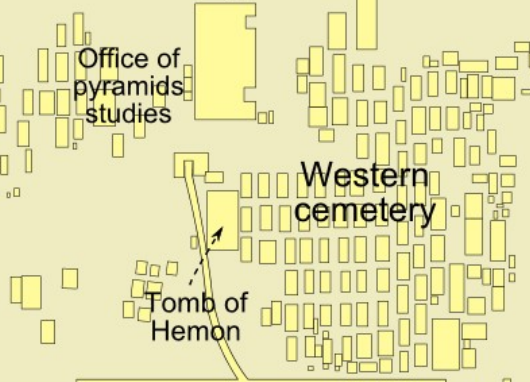

# Great Pyramid of Khufu





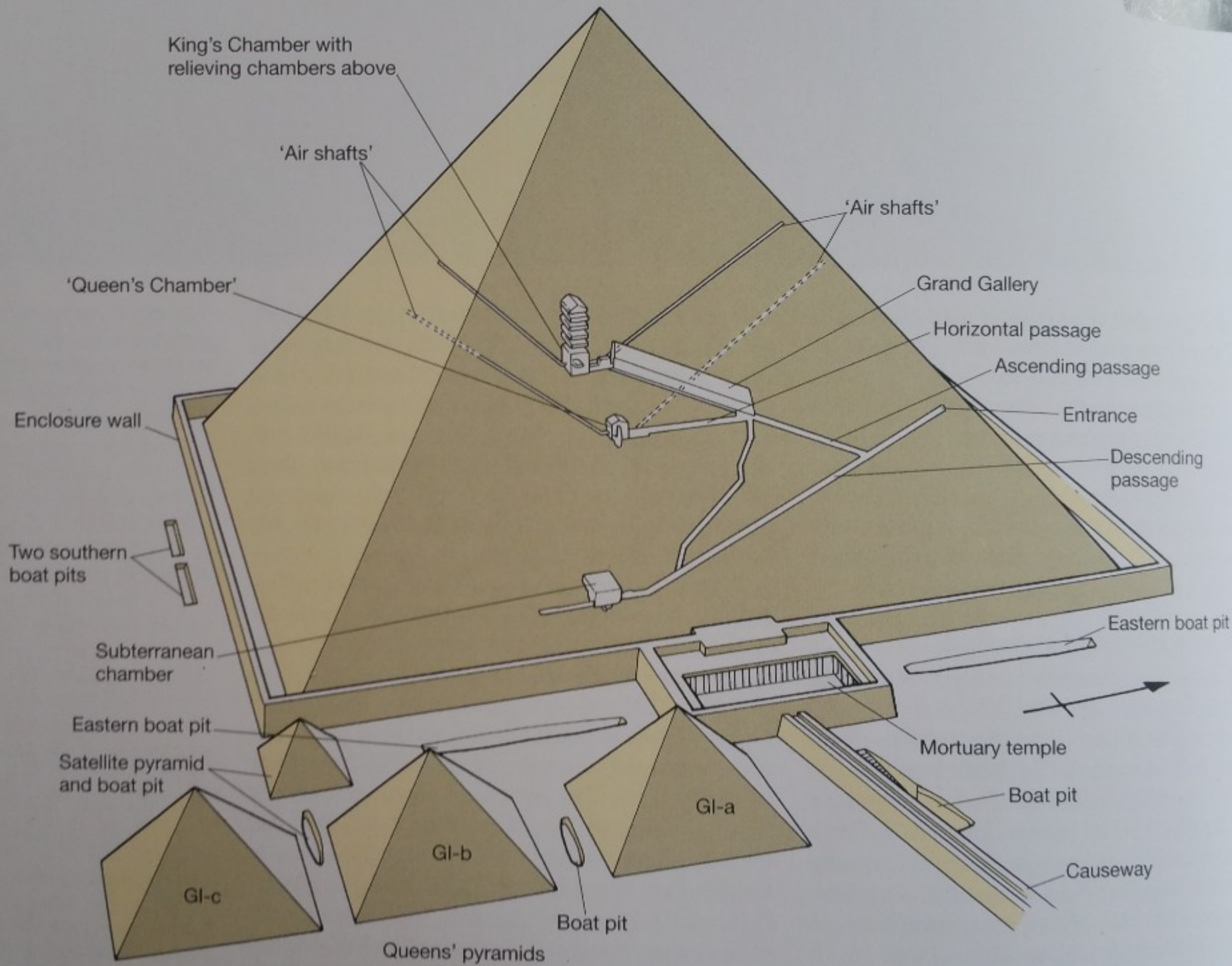

















# Pyramid of Khafre











# Pyramid of Unas









# The Pyramid Texts

The sky's doorway has been opened,  
The Cool Waters' door has been pulled open  
For Horus of the gods at daybreak,  
That he might emerge into the Marsh of Reeds  
And become clean in the Marsh of Reeds.

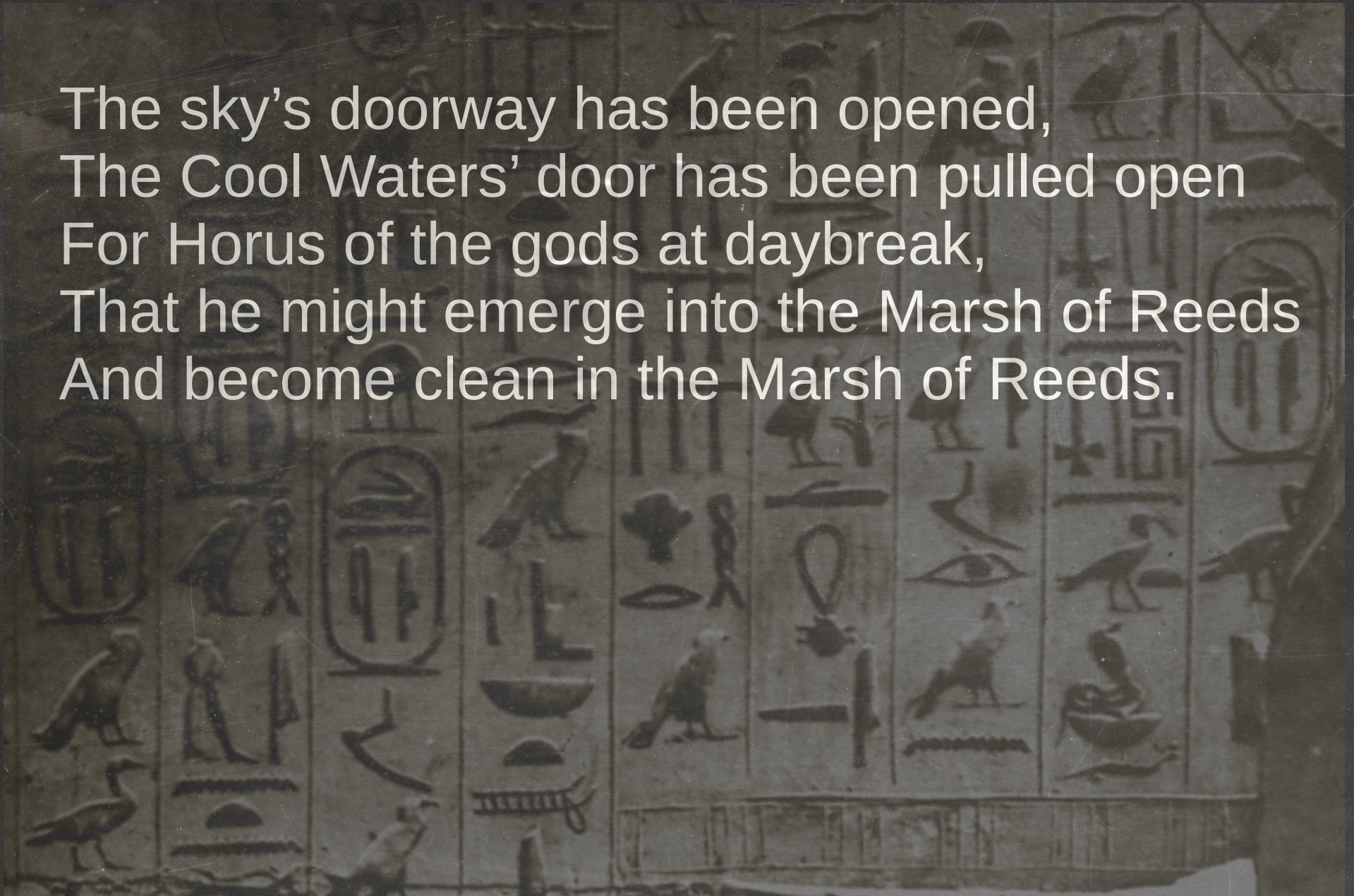





# The Pyramid Texts

Unas! You have not gone away dead,  
You have gone away alive!

Sit on Osiris' chair, with your baton in your arm,  
Govern the living!

With your lotus scepter in your arm,  
Govern those of the inaccessible places!

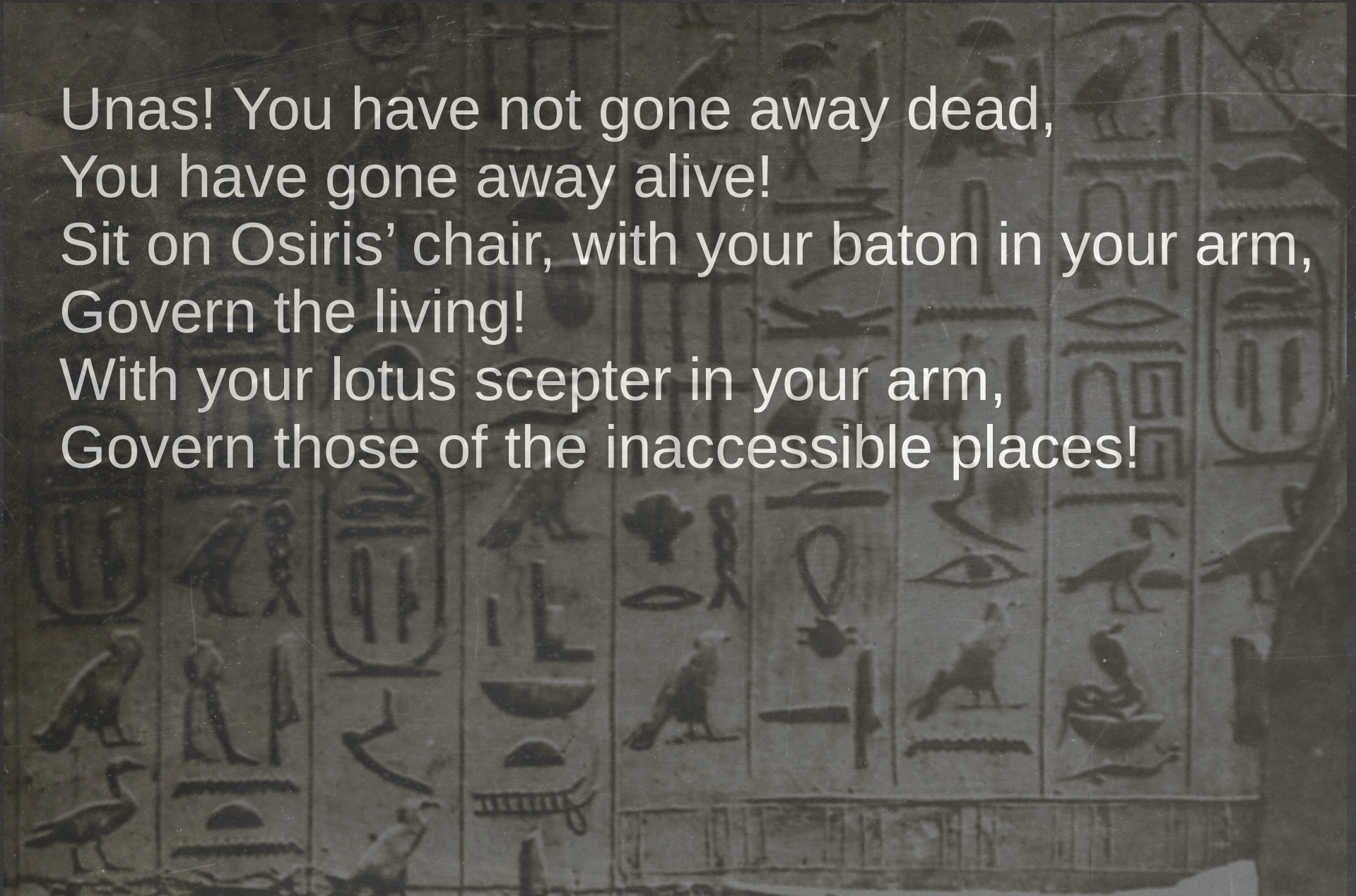



# The Pyramid Texts

The sky's two reedfloats have been set for the Sun,  
That he might cross on them to the Horizon.

The sky's two reedfloats have been set for Horus,  
That he might cross on them to where the Sun is.

The sky's two reedfloats have been set for Unas,  
That he might cross on them to where Horus is,  
To where the Sun is.

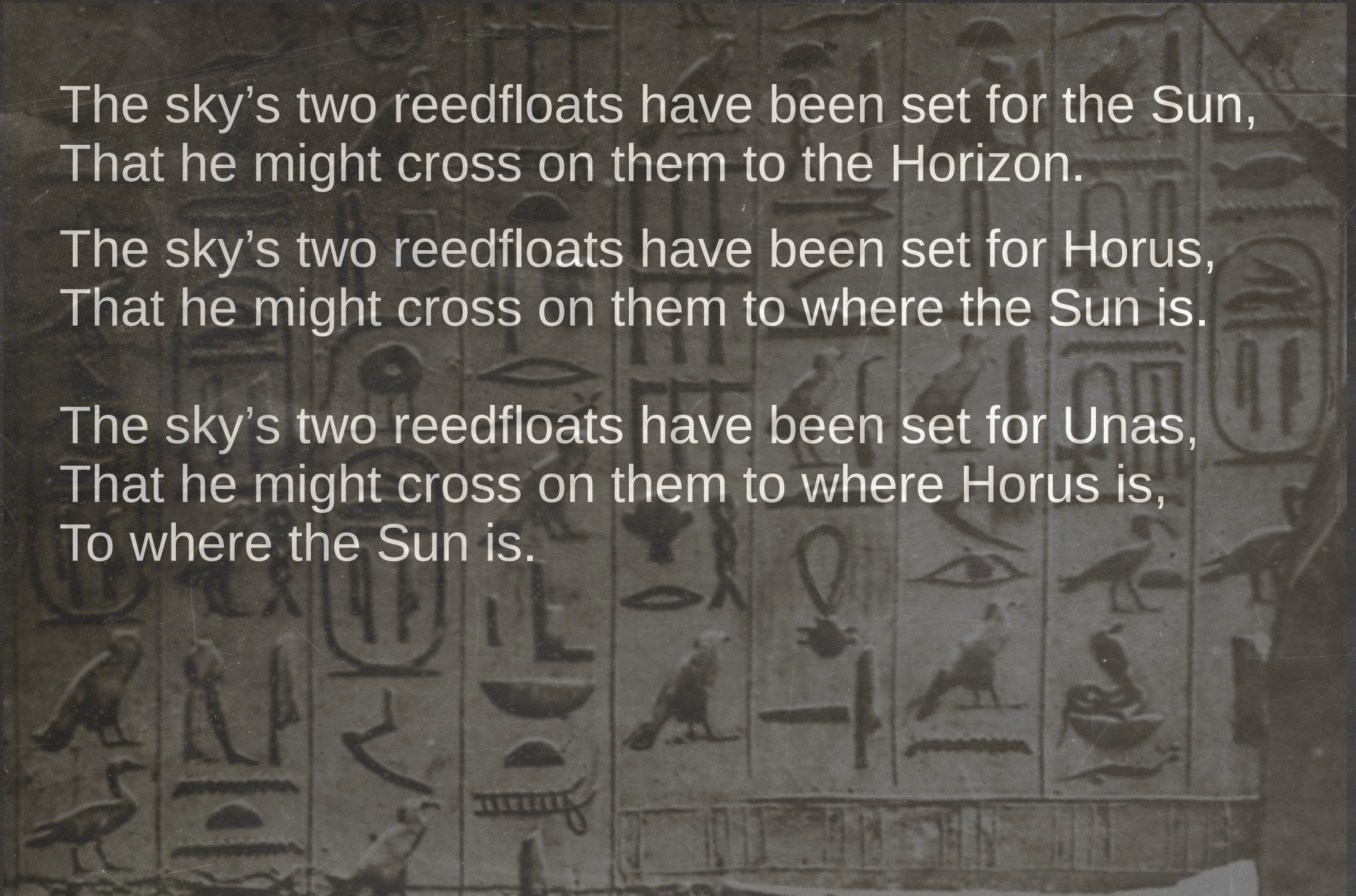

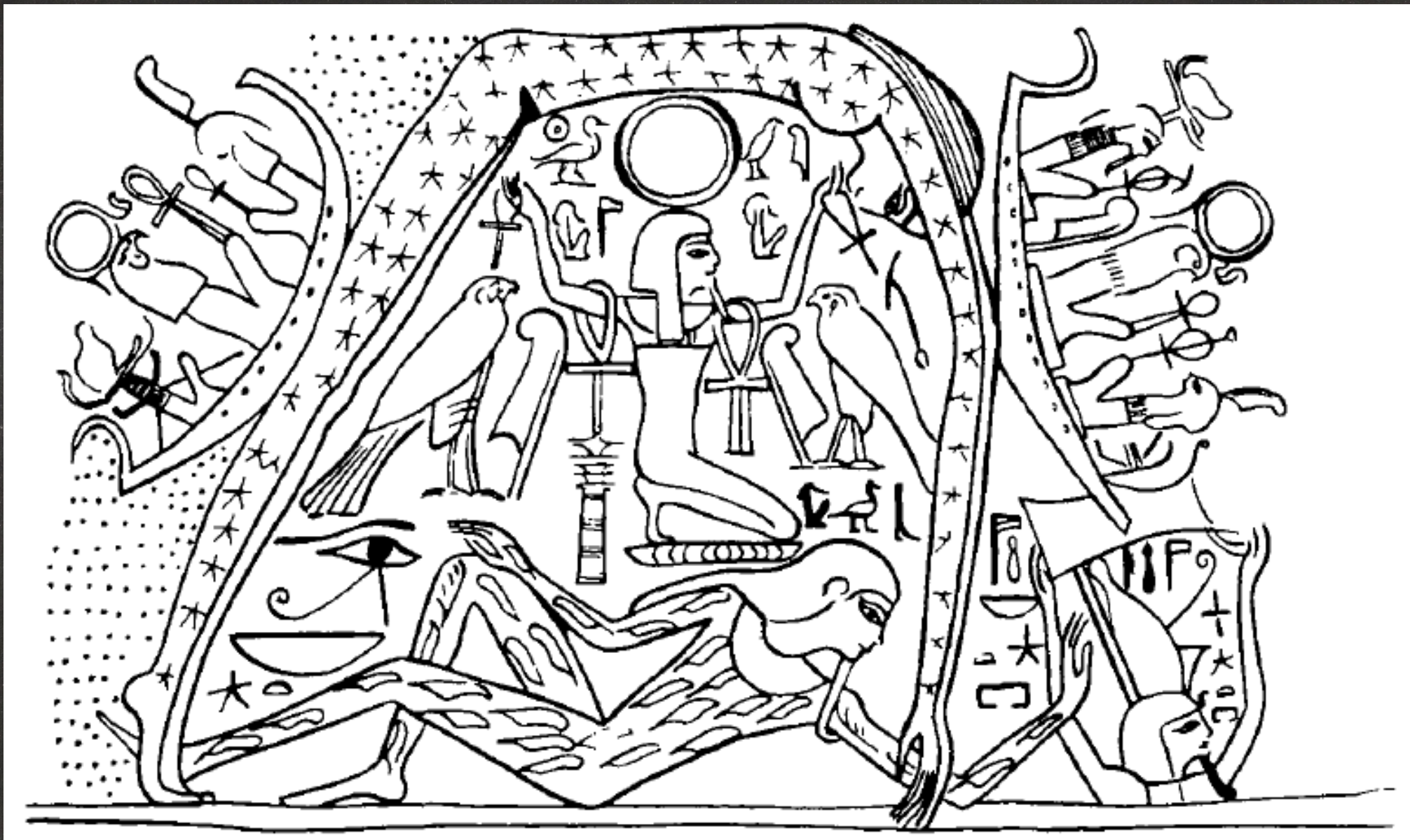

# The Pyramid Texts

The sky has grown cloudy,  
The stars obscured,  
The sky's arcs have quaked,  
The horizon's bones shaken,  
And those who move have grown still,  
Having seen Unas rising as Ba,  
As the god who lives on his fathers  
And feeds on his mothers.  
Unas is the one who eats people and lives on gods...  
Unas is the one who eats their magic...





# Nubian pyramids at Meroe



















# Khaemwaset, son of Ramesses II



# Herodotus (485-426 BCE)

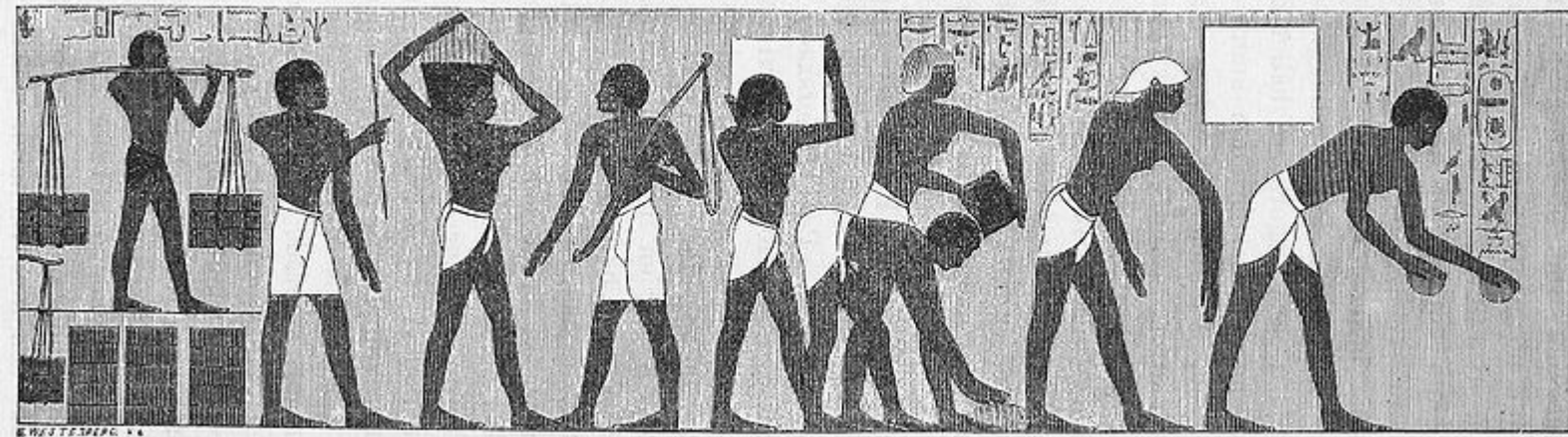
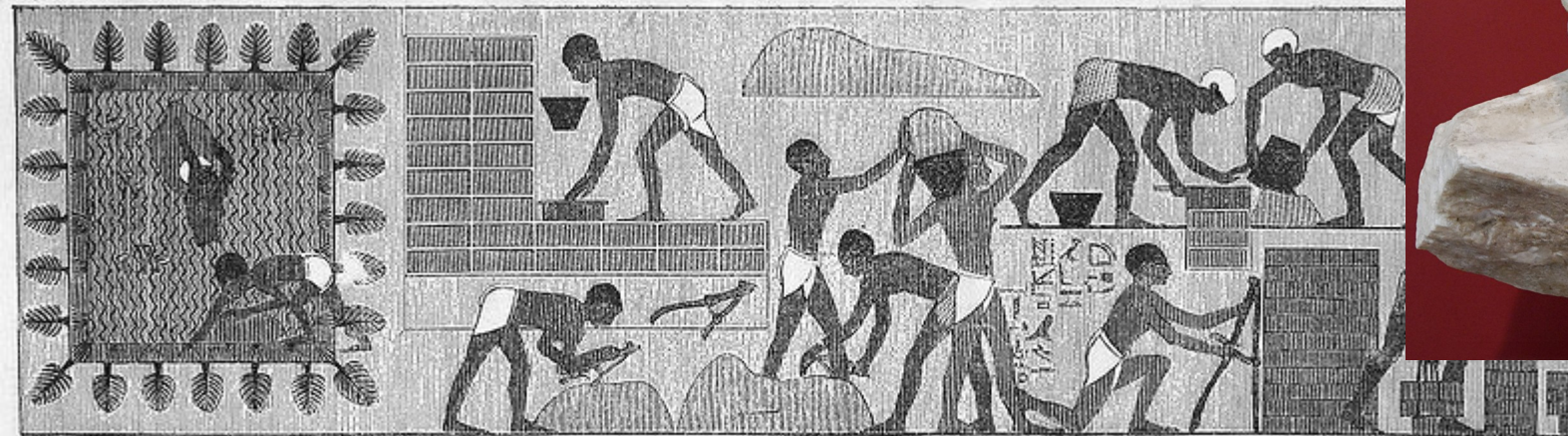
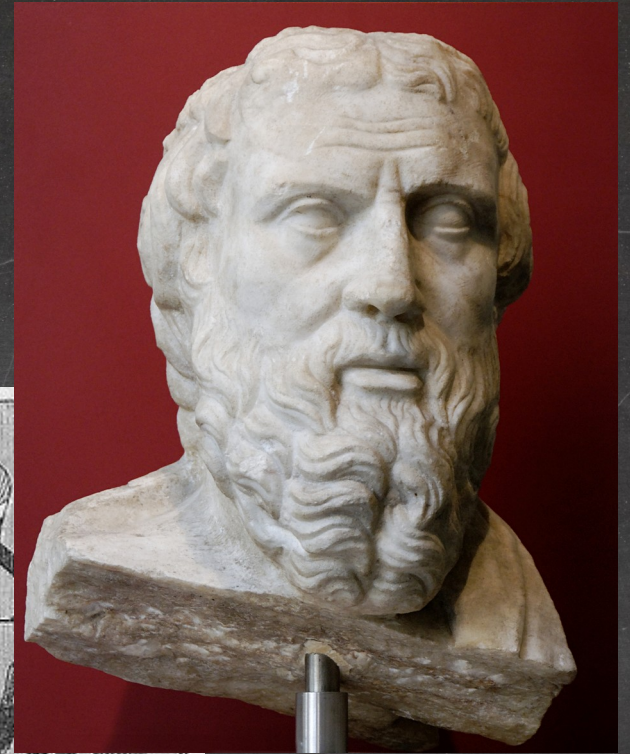

# Josephus (37 – 100 CE)







St. Mark's,  
Venice



# The Renaissance View

John Greaves (1602-52)

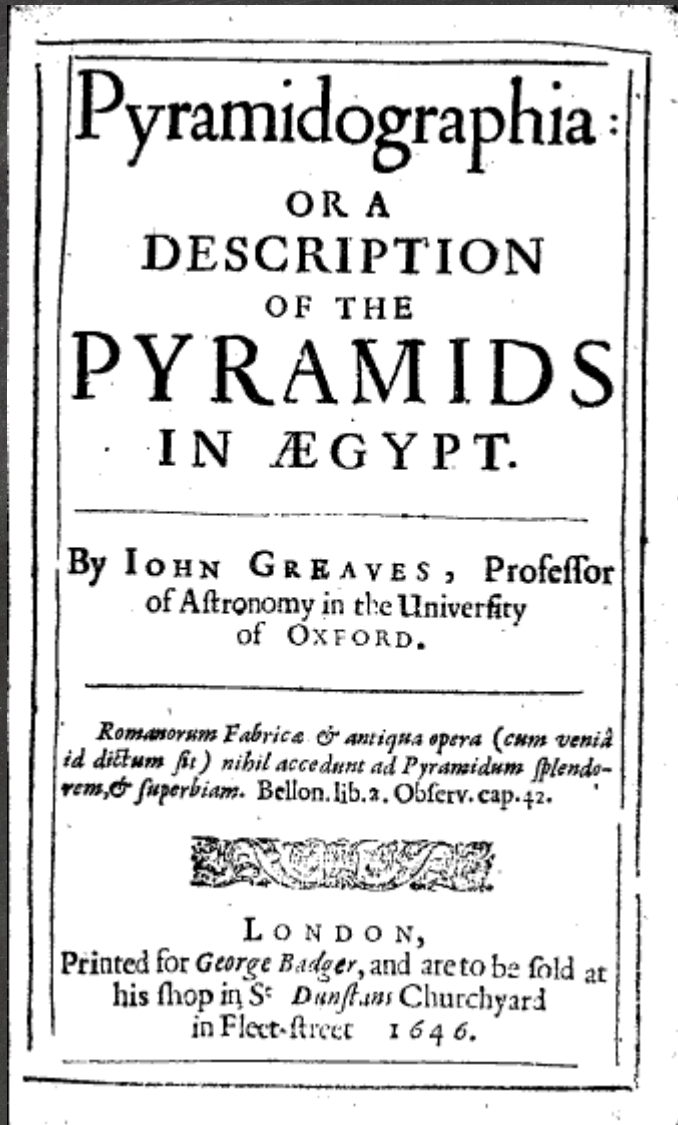



# Napoleon Bonaparte (1769-1821)





Jean-Léon Gérôme, Napoleon devant le Sphinx (1867-1868)

# DESCRIPTION DE L'ÉGYPTE,

OU

## RECUEIL

DES OBSERVATIONS ET DES RECHERCHES

QUI ONT ÉTÉ FAITES EN ÉGYPTE

PENDANT L'EXPÉDITION DE L'ARMÉE FRANÇAISE,

PUBLIÉ

PAR LES ORDRES DE SA MAJESTÉ L'EMPEREUR

NAPOLÉON LE GRAND.

I - PLANCHES.



A PARIS,  
DE L'IMPRIMERIE IMPÉRIALE.

M. DCCC. IX.



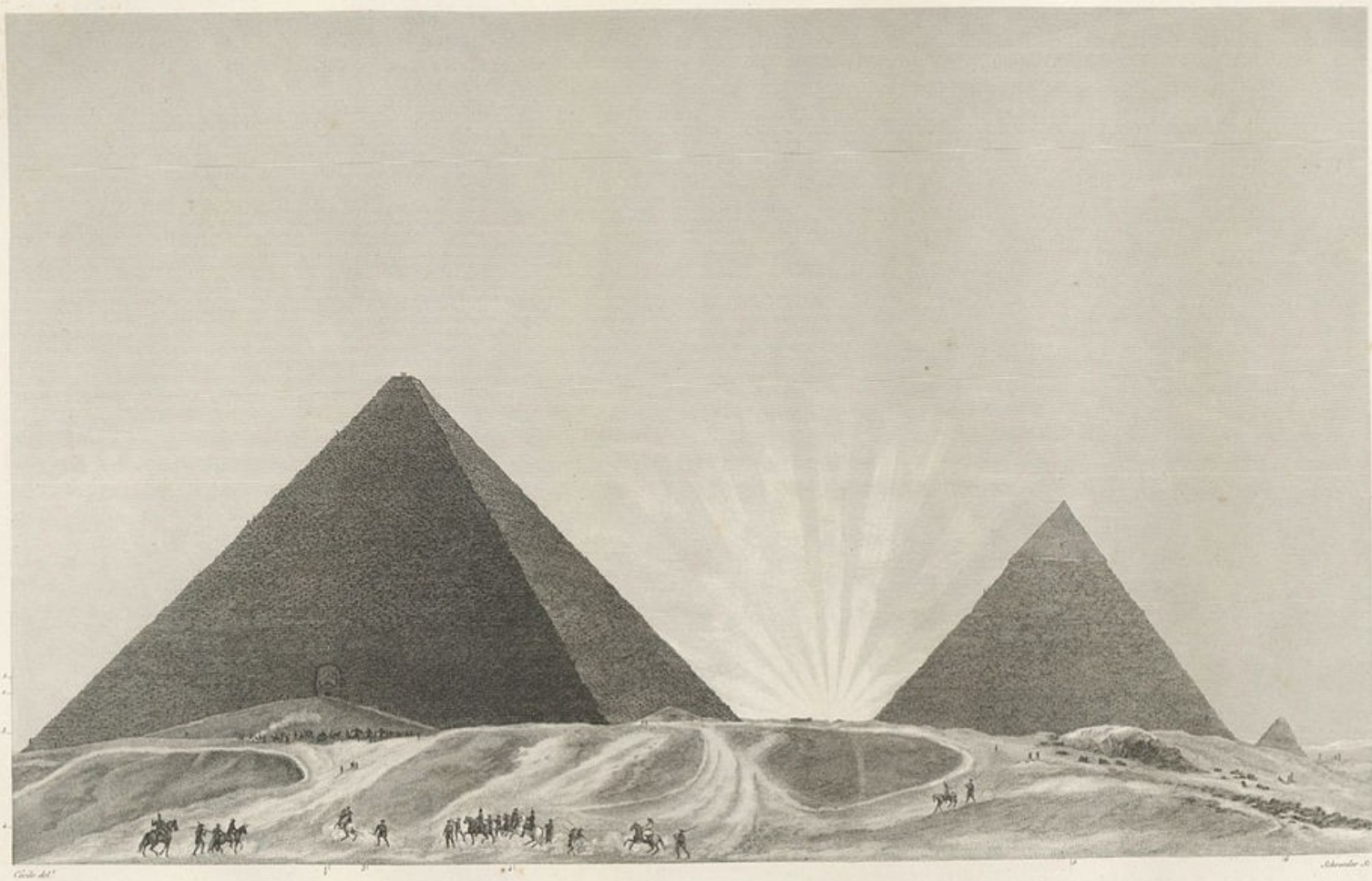

VUE DE L'ENTRÉE DE LA GRANDE PYRAMIDE, PRISE AU SOLEIL LEVANT.

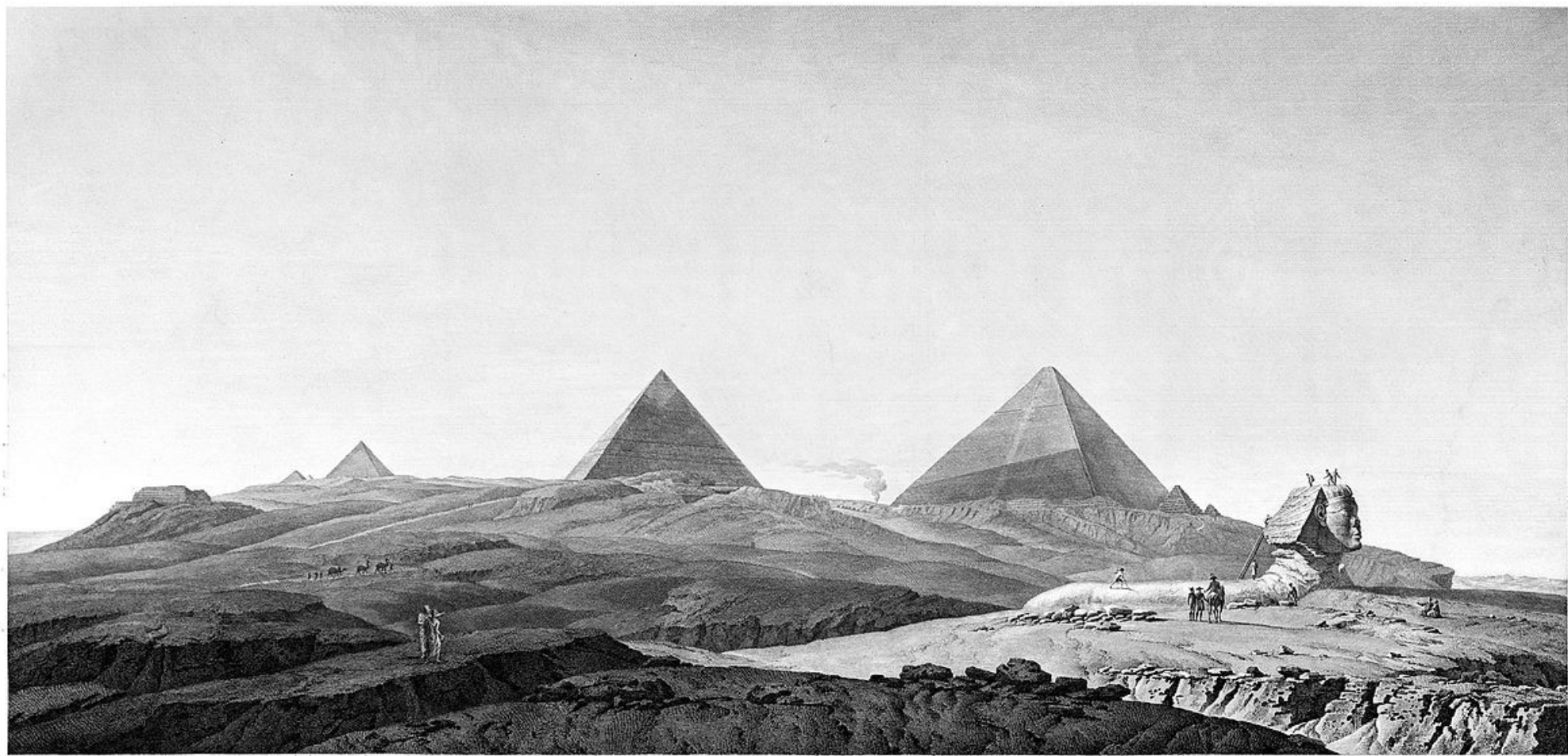

VUE GÉNÉRALE DES PYRAMIDES ET DU SPHINX, PRISE AU SOLEIL COUCHANT.



VUE DU SPHINX ET DE LA GRANDE PYRAMIDE, PRISE DU SUD-EST.

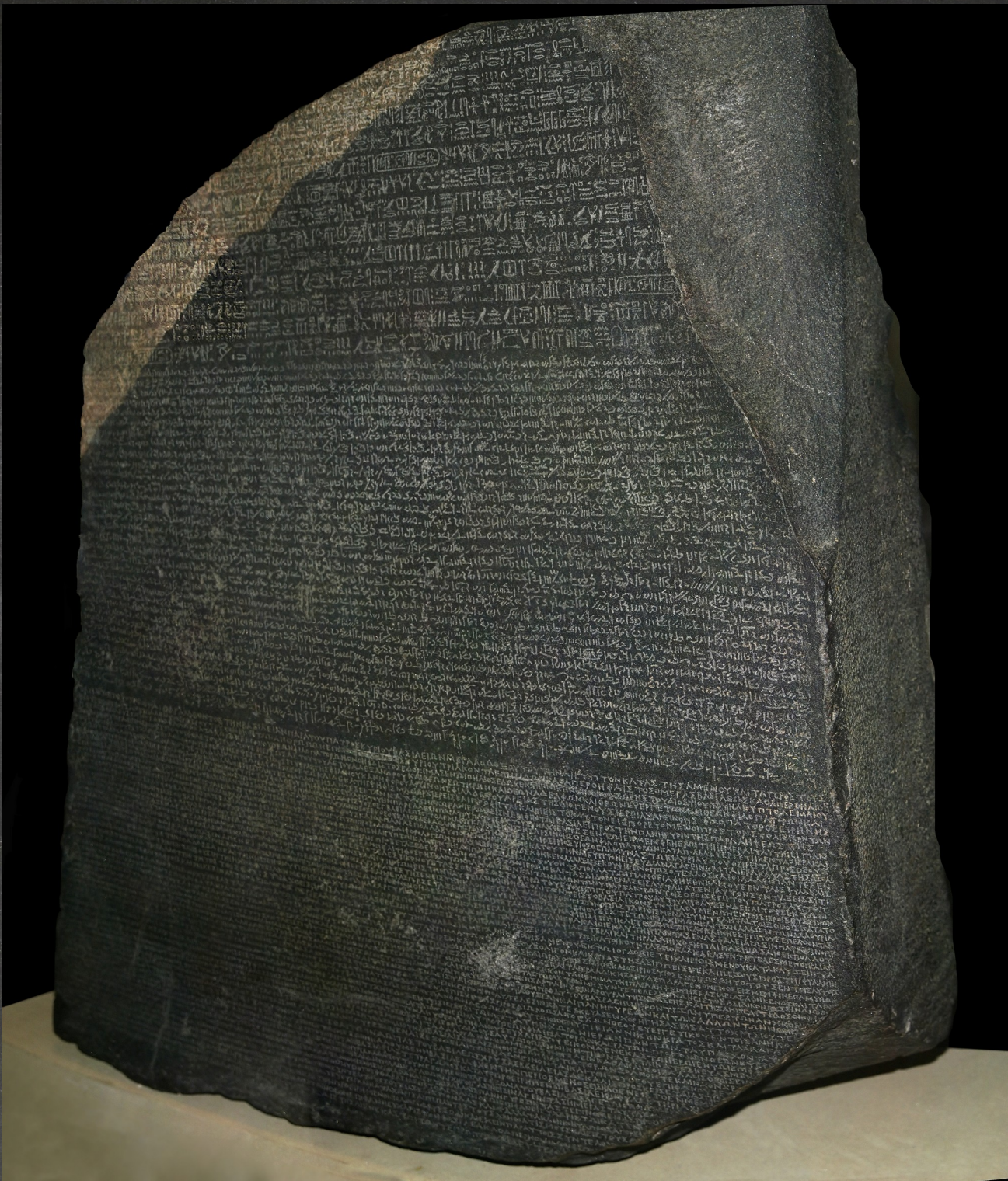





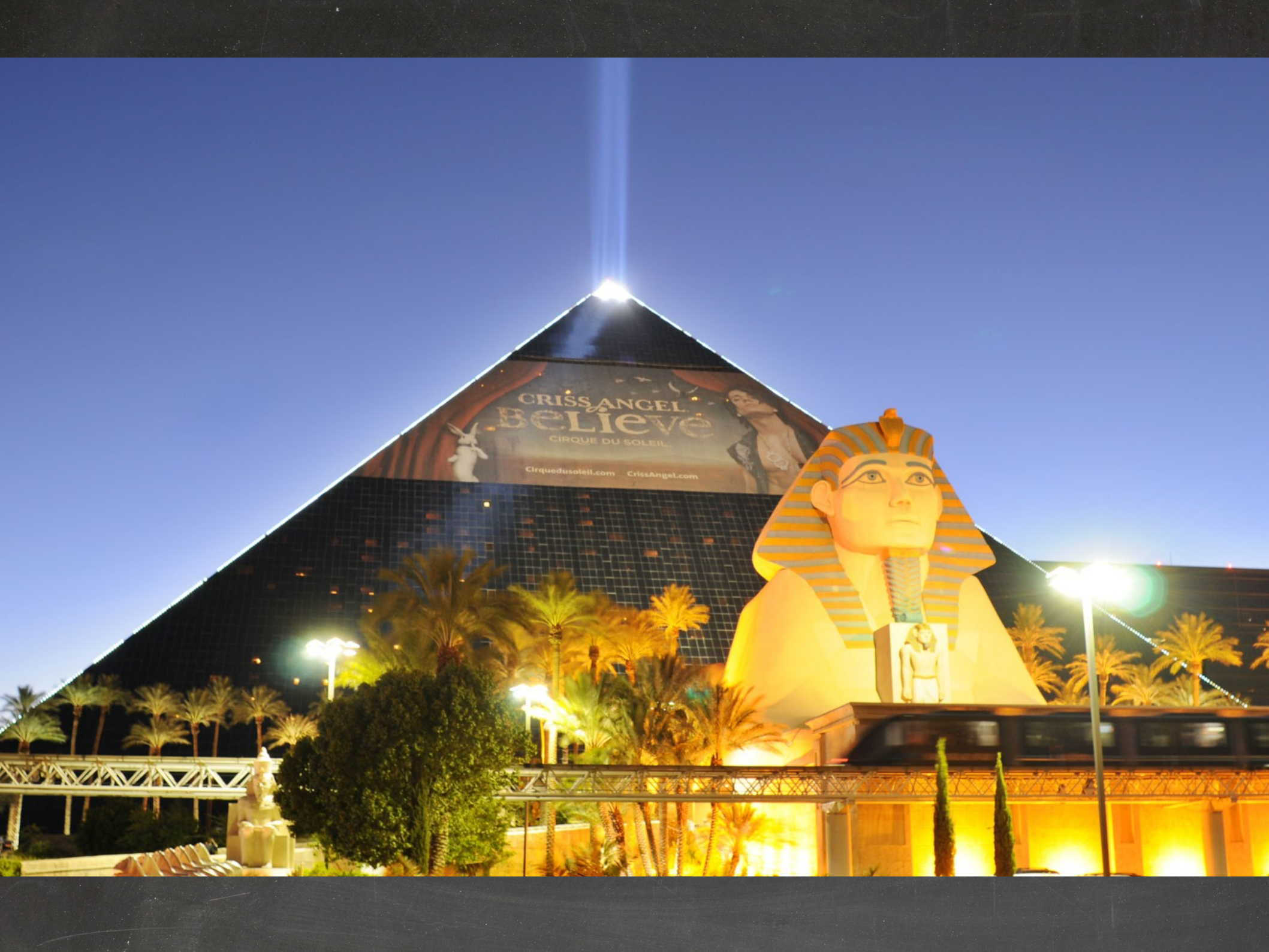

CRISS ANGEL  
BELIEVE  
CIRQUE DU SOLEIL

Cirquedusoleil.com CrissAngel.com

